



PRODUKTBROSCHÜRE | BROCHURE DE PRODUITS

# TÜRENTRÄUME AUF EINEN BLICK

DES PORTES DE RÊVE AU PREMIER REGARD

# Themen

## Thèmes

Seite 04–05 Die Premiumkante | Le chant Premium

Seite 06–35 **CPL-PROGRAMM | GAMME CPL**  
Seite 08–31 STANDARD-PROGRAMM | PROGRAMME STANDARD  
Seite 34–35 Gesamtübersicht CPL | Vue d'ensemble CPL

Seite 36–59 **WEISSLACK-PROGRAMM | GAMME BLANC LAQUÉ**  
Seite 38–41 STANDARD-PROGRAMM | GAMME STANDARD  
Seite 42–49 ELEGANCE-PROGRAMM | GAMME ELEGANCE  
Seite 50–53 ROYAL-PROGRAMM | GAMME ROYAL  
Seite 56–59 Gesamtübersicht WEISSLACK | Vue d'ensemble BLANC LAQUÉ

Seite 60–69 **SCHICHTSTOFF-PROGRAMM | GAMME STRATIFIÉ**  
Seite 62–63 STANDARD-PROGRAMM | GAMME STANDARD  
Seite 68–69 Gesamtübersicht SCHICHTSTOFF | Vue d'ensemble HPL

Seite 70–73 **TÜREN IN FUNKTION | PORTES TECHNIQUES**

Seite 74–95 **TECHNISCHE DETAILS | DÉTAILS TECHNIQUES**  
Seite 76–79 Glas-Übersicht | Aperçu des verres  
Seite 80–91 Beschläge und Schiebetürlösungen | Ferrures et solutions de portes coulissantes  
Seite 92–95 Zargenausführungen, Bänder | Modèles de châssis, paumelles

Seite 96–99 Masse | Dimensions

# Uneingeschränkt umweltverträglich

## Totalement écologiques

Durch ihre speziellen Oberflächen mit besonderen Schutzeigenschaften sind unsere CPL-Innentüren äusserst beständig gegen mechanische Beanspruchung: Sie sind kratz-, stoss- und abriebfest, unempfindlich gegenüber Feuchtigkeit- und Hitzeinwirkung – und natürlich gegen Schmutz.

Diese innovativen Oberflächeneigenschaften und die grosse Auswahl an CPL-Dekoren machen unsere CPL-Innentüren zu den perfekten Türen für jedes Raumkonzept: Sie unterstützen Sie bei der Gestaltung Ihrer Räume und bei der Eröffnung neuer Wohnwelten.

Gut zu wissen: Ein bewusster Umgang mit Ressourcen und die fast ausschliessliche Verwendung lösungsmittelfreier Lacke sind für uns selbstverständlich. Unsere Produkte tragen das eco-Label des ECO Instituts. Damit sind wir einer der erste Türenhersteller, der eine Umweltverträglichkeit seiner Produkte nachgewiesen hat. Zudem sind wir PEFC- und FSC®-zertifiziert und tragen somit zur verantwortungsvollen Waldwirtschaft bei.

Grâce à leurs finitions spéciales aux propriétés protectrices particulières nos portes intérieures CPL sont extrêmement résistantes aux sollicitations mécaniques : elles résistent aux rayures, aux chocs et à l'abrasion. De plus, elles sont insensibles à l'humidité et à la chaleur. Et bien sûr à la saleté.

Ces propriétés de finition innovantes et le grand choix de films CPL font de nos portes intérieures CPL les portes parfaites pour chaque concept d'espace : elles vous aident à aménager vos pièces et à ouvrir de nouveaux univers de vie.

Bon à savoir : une gestion consciente des ressources et l'utilisation presque exclusive de vernis sans solvants sont pour nous une évidence. Nos produits portent le label eco de l'institut ECO. Nous sommes ainsi l'un des premiers fabricants de portes à avoir prouvé la compatibilité de nos produits avec l'environnement. De plus, nous sommes certifiés PEFC et FSC® et contribuons ainsi à une gestion responsable des forêts.

**ARBONIA**   
Doors-Suisse





# Die Premiumkante Chant Premium

erstklassige Kantentechnik für zahlreiche Einsatzgebiete  
technologie de pointe des chants de porte pour différents usages

Mit der Nullfugentechnik von Arbonia entstand erstmals eine funktionelle und designorientierte Türkante.  
La technologie à joint zéro de Arbonia a permis de créer pour la première fois une porte fonctionnelle et design.

## DIE BESONDERHEITEN DER ARBONIA PREMIUM-KANTE AUF EINEN BLICK:

- kleiner Radius an Aufdeck- und Falzseite
- dauerhaft fugenlose Optik
- extreme Strapazierfähigkeit
- beste Reinigungseigenschaften
- auch als KiTa-Kante einsetzbar

## LES AVANTAGES DU CHANT PREMIUM DE ARBONIA :

- petit rayon sur la face de recouvrement et la feuillure
- aspect sans joint visible
- résistance extrême à l'usure
- très facile d'entretien
- également utilisable dans les crèches

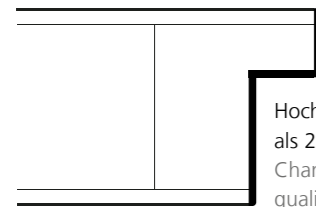

Hochwertige Premiumkante  
als 2 mm Dickkante  
Chant Premium de haute  
qualité épaisseur 2 mm

PREMIUMKANTE  
CHANT PREMIUM

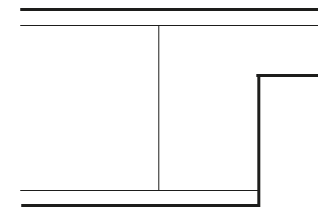

STANDARDKANTE  
CHANT STANDARD

Um eine perfekte und somit nicht sichtbare Fuge an der Türkante zu erhalten, haben wir bei Arbonia die Entwicklung der Nullfugentechnik kontinuierlich vorangetrieben. Mit kleinem Radius an Aufdeck- und Falzseite der Tür, einer dauerhaft fugenlosen Optik, extremer Strapazierfähigkeit und besten Reinigungseigenschaften ist unsere Premiumkante eine klare Entscheidung für höchste Qualität. Passende Türzargen mit kleinem Radius runden das Sortiment stimmig ab.

Afin d'obtenir un joint parfait et donc invisible sur le bord de la porte, nous avons, chez Arbonia, développé la technologie du joint zéro. Avec un petit rayon du côté du recouvrement et de la feuillure de la porte, un aspect sans joint, une résistance extrême et des propriétés d'entretien optimales, notre chant Premium est un choix évident de qualité supérieure. Les cadres, faux-cadres et embrasures de porte assortis à petit rayon complètent l'assortiment de manière harmonieuse.



Erhöhte  
Stoßfestigkeit  
Résistance aux chocs



Hohe  
Reinigungsfreundlichkeit  
Facile d'entretien



Erhöhte  
Feuchtebeständigkeit  
Résistance à l'humidité



Verringerte  
Verletzungsgefahr  
Risque de blessures réduit



Verbesserte  
Langlebigkeit  
Longévité améliorée

# Premiumkante – Immer schöne Türen Chant Premium – Immer schöne Türen

Mitten im Leben –  
**Stoßegal**

Das Original von Arbonia  
mit Nullfugentechnik



## Kantenfarbe | Teinte du chant de porte

PK2 WEISS 9016 PK2 BLANC 9016	PK2 WEISS 9010 PK2 BLANC 9010	PK2 KARO WHITE PK2 KARO WHITE	PK2 KARO BEIGE PK2 KARO BEIGE	PK2 KARO GREY PK2 KARO GREY	PK2 KARO DARK PK2 KARO DARK	PK2 SCHWARZ PK2 NOIR	PK2 GRAPHITGRAU PK2 GRIS GRAPHITE
PK2 STAUBGRAU PK2 GRIS POUSSIÈRE	PK2 SEIDENGRAU PK2 GRIS SOIE	PK2 SILBERGRAU PK2 GRIS ARGENTÉ	PK2 HELLBRAUN PK2 BRUN CLAIR	PK2 MITTELBRAUN PK2 BRUN MOYEN	PK2 EICHEBRAUN PK2 BRUN CHÊNE	PK2 DUNKELBRAUN PK2 BRUN FONCÉ	

## CPL-Programm | Gamme CPL



Mit unserem CPL-Programm bieten wir Ihnen die Basis unserer Türen-Kompetenz und eine grosse Vielfalt an Formen, Funktionen und Details.

Avec notre gamme CPL, nous vous proposons la base de notre compétence en matière de portes et une grande diversité de formes, de fonctions et de détails.



STANDARD  
CPL Weisslack 9016 & 9010

Klassische Eleganz  
Élégance classique

QUERSCHNITT 9016 | COUPE TRANSVERSALE 9016

KLEINE RUNDKANTE | PETIT CHANT ARRONDI

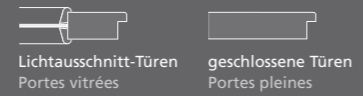

PREMIUMKANTE | CHANT PREMIUM

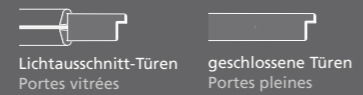

QUERSCHNITT 9010 | COUPE TRANSVERSALE 9010

RUNDKANTE | CHANT ARRONDI



PREMIUMKANTE | CHANT PREMIUM

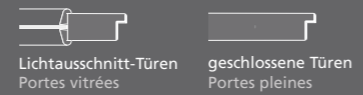

BESCHLAG  
NOVO

GRAPHITSCHWARZ  
NOIR GRAPHITE



BB/RZ/WC



smart2lock

EDELSTAHL MATT  
ACIER INOXYDABLE MAT



BB/RZ/WC



smart2lock



**MODELL**  
**OBERFLÄCHE**  
**GLAS**  
**ZARGE**  
**BESCHLAG**  
**MODÈLE**  
**FINITION**  
**VERRE**  
**CHÂSSIS**  
**FERRURE**

**1** STANDARD TB-DA  
CPL Weisslack 9016  
-  
FU-RFKR-60/16  
NOVO, Graphitschwarz  
PORTES STANDARD TB-DA  
CPL Blanc laqué 9016  
-  
FU-RFKR-60/16  
NOVO, noir graphite

**2** STANDARD TB-LA-DA+SP4  
CPL Weisslack 9016  
FLOAT SATINIERT, Ornamentglas  
FU-RFKR-60/16  
NOVO, Graphitschwarz  
PORTES STANDARD TB-LA-DA+SP4  
CPL Blanc laqué 9016  
FLOAT SATINÉ, verre imprimé  
FU-RFKR-60/16  
NOVO, noir graphite

**3** STANDARD TB-LA-DA  
CPL Weisslack 9016  
FLOAT SATINIERT, Ornamentglas  
FU-RFKR-60/16  
NOVO, Graphitschwarz  
PORTES STANDARD TB-LA-DA  
CPL Blanc laqué 9016  
FLOAT SATINÉ, verre imprimé  
FU-RFKR-60/16  
NOVO, noir graphite

**4** STANDARD TB-LA2-DA  
CPL Weisslack 9016  
FLOAT SATINIERT, Ornamentglas  
FU-RFKR-60/16  
NOVO, Graphitschwarz  
PORTES STANDARD TB-LA2-DA  
CPL Blanc laqué 9016  
FLOAT SATINÉ, verre imprimé  
FU-RFKR-60/16  
NOVO, noir graphite

**5** STANDARD TB-LA25-DA  
CPL Weisslack 9010  
FLOAT SATINIERT, Ornamentglas  
FU-RF 60/16  
NOVO, Edelstahl Matt  
PORTES STANDARD TB-LA25-DA  
CPL Blanc laqué 9010  
FLOAT SATINÉ, verre imprimé  
FU-RF 60/16  
NOVO, acier inoxydable mat

**6** STANDARD TB-LA3-DA  
CPL Weisslack 9010  
FLOAT SATINIERT, Ornamentglas  
FU-RF 60/16  
NOVO, Edelstahl Matt  
PORTES STANDARD TB-LA3-DA  
CPL Blanc laqué 9010  
FLOAT SATINÉ, verre imprimé  
FU-RF 60/16  
NOVO, acier inoxydable mat

**7** STANDARD TB-LA1-DA  
CPL Weisslack 9010  
FLOAT SATINIERT, Ornamentglas  
FU-RF 60/16  
NOVO, Edelstahl Matt  
PORTES STANDARD TB-LA1-DA  
CPL Blanc laqué 9010  
FLOAT SATINÉ, verre imprimé  
FU-RF 60/16  
NOVO, acier inoxydable mat

**8** STANDARD TB-DA  
CPL Weisslack 9010  
-  
FU-RF-60/16  
NOVO, Edelstahl Matt  
PORTES STANDARD TB-DA  
CPL Blanc laqué 9010  
-  
FU-RF-60/16  
NOVO, acier inoxydable mat

STANDARD  
CPL Graphitgrau & Staubgrau

Für einen modernen Wohnstil  
Pour un style de vie moderne

Eindrucksvolle Oberflächen in neuen Grau-Nuancen.  
Des finitions impressionnantes dans de nouvelles  
nuances de gris.

QUERSCHNITT | COUPE TRANSVERSALE

KLEINE RUNDKANTE | PETIT CHANT ARRONDI



PREMIUMKANTE | CHANT PREMIUM



BESCHLAG  
MONO

GRAPHITSCHWARZ  
NOIR GRAPHITE



BB/RZ/WC



smart2lock

EDELSTAHL MATT  
ACIER INOXYDABLE MAT



BB/RZ/WC



smart2lock



**MODELL**  
**OBERFLÄCHE**  
**GLAS**  
**ZARGE**  
**BESCHLAG**  
**MODÈLE**  
**FINITION**  
**VERRE**  
**CHÂSSIS**  
**FERRURE**

**1** STANDARD TB-DA  
CPL Graphitgrau  
-  
FU-RFKR-60/16  
MONO, Graphitschwarz  
PORTES STANDARD TB-DA  
CPL Gris graphite  
-  
FU-RFKR-60/16  
MONO, noir graphite

**2** STANDARD TB-LA-DA+SP4  
CPL Graphitgrau  
FLOAT SATINIERT, Ornamentglas  
FU-RFKR-60/16  
MONO, Graphitschwarz  
PORTES STANDARD TB-LA-DA+SP4  
CPL Gris graphite  
FLOAT SATINÉ, verre imprimé  
FU-RFKR-60/16  
MONO, noir graphite

**3** STANDARD TB-LA-DA  
CPL Graphitgrau  
FLOAT SATINIERT, Ornamentglas  
FU-RFKR-60/16  
MONO, Graphitschwarz  
PORTES STANDARD TB-LA-DA  
CPL Gris graphite  
FLOAT SATINÉ, verre imprimé  
FU-RFKR-60/16  
MONO, noir graphite

**4** STANDARD TB-LA2-DA  
CPL Graphitgrau  
FLOAT SATINIERT, Ornamentglas  
FU-RFKR-60/16  
MONO, Graphitschwarz  
PORTES STANDARD TB-LA2-DA  
CPL Gris graphite  
FLOAT SATINÉ, verre imprimé  
FU-RFKR-60/16  
MONO, noir graphite

**5** STANDARD TB-LA2S-DA  
CPL Staubgrau  
FLOAT SATINIERT, Ornamentglas  
FU-RFKR-60/16  
MONO, Edeldahl matt  
PORTES STANDARD TB-LA2S-DA  
CPL Gris poussière  
FLOAT SATINÉ, verre imprimé  
FU-RFKR-60/16  
MONO, acier inoxydable mat

**6** STANDARD TB-LA3-DA  
CPL Staubgrau  
FLOAT SATINIERT, Ornamentglas  
FU-RFKR-60/16  
MONO, Edeldahl matt  
PORTES STANDARD TB-LA3-DA  
CPL Gris poussière  
FLOAT SATINÉ, verre imprimé  
FU-RFKR-60/16  
MONO, acier inoxydable mat

**7** STANDARD TB-LA1-DA  
CPL Staubgrau  
FLOAT SATINIERT, Ornamentglas  
FU-RFKR-60/16  
MONO, Edeldahl matt  
PORTES STANDARD TB-LA1-DA  
CPL Gris poussière  
FLOAT SATINÉ, verre imprimé  
FU-RFKR-60/16  
MONO, acier inoxydable mat

**8** STANDARD TB-DQ  
CPL Staubgrau  
-  
FU-RFKR-60/16  
MONO, Edeldahl matt  
PORTES STANDARD TB-DQ  
CPL Gris poussière  
-  
FU-RFKR-60/16  
MONO, acier inoxydable mat



**STANDARD**  
CPL Silbergrau & Seidengrau

Die graue Eminenz für den puristischen Wohnstil.

L'éminence grise pour un intérieur puriste.

Die Oberfläche für zeitloses, schlichtes Design.  
La finition pour un design sobre et intemporel.

**QUERSCHNITT | COUPE TRANSVERSALE**

**KLEINE RUNDKANTE | PETIT CHANT ARRONDI**

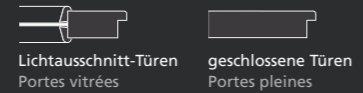

**PREMIUMKANTE | CHANT PREMIUM**

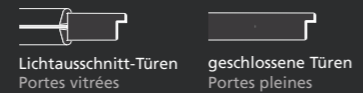

**BESCHLAG**  
**NEO**

**GRAPHITSCHWARZ**  
NOIR GRAPHITE



BB/RZ/WC



smart2lock

**EDELSTAHL MATT**  
ACIER INOXYDABLE MAT



BB/RZ/WC



smart2lock



**MODELL** 1 STANDARD TB-DA  
**OBERFLÄCHE** CPL Silbergrau  
**GLAS** -  
**ZARGE** FU-RFKR-60/16  
**BESCHLAG** NEO, Graphitschwarz  
**MODÈLE** PORTES STANDARD TB-DA  
**FINITION** CPL Gris argenté  
**VERRE** -  
**CHÂSSIS** FU-RFKR-60/16  
**FERRURE** NEO, noir graphite

**MODELL** 2 STANDARD TB-LA-DA+SP4  
**OBERFLÄCHE** CPL Silbergrau  
**GLAS** FLOAT SATINIERT, Ornamentglas  
**ZARGE** FU-RFKR-60/16  
**BESCHLAG** NEO, Graphitschwarz  
**MODÈLE** PORTES STANDARD TB-LA-DA+SP4  
**FINITION** CPL Gris argenté  
**VERRE** FLOAT SATINÉ, verre imprimé  
**CHÂSSIS** FU-RFKR-60/16  
**FERRURE** NEO, noir graphite

**MODELL** 3 STANDARD TB-LA-DA  
**OBERFLÄCHE** CPL Silbergrau  
**GLAS** FLOAT SATINIERT, Ornamentglas  
**ZARGE** FU-RFKR-60/16  
**BESCHLAG** NEO, Graphitschwarz  
**MODÈLE** PORTES STANDARD TB-LA-DA  
**FINITION** CPL Gris argenté  
**VERRE** FLOAT SATINÉ, verre imprimé  
**CHÂSSIS** FU-RFKR-60/16  
**FERRURE** NEO, noir graphite

**MODELL** 4 STANDARD TB-LA2-DA  
**OBERFLÄCHE** CPL Silbergrau  
**GLAS** FLOAT SATINIERT, Ornamentglas  
**ZARGE** FU-RFKR-60/16  
**BESCHLAG** NEO, Graphitschwarz  
**MODÈLE** PORTES STANDARD TB-LA2-DA  
**FINITION** CPL Gris argenté  
**VERRE** FLOAT SATINÉ, verre imprimé  
**CHÂSSIS** FU-RFKR-60/16  
**FERRURE** NEO, noir graphite

**MODELL** 5 STANDARD TB-LA2S-DA  
**OBERFLÄCHE** CPL Seidengrau  
**GLAS** FLOAT SATINIERT, Ornamentglas  
**ZARGE** FU-RFKR-60/16  
**BESCHLAG** NEO, Edelstahl Matt  
**MODÈLE** PORTES STANDARD TB-LA2S-DA  
**FINITION** CPL Gris soie  
**VERRE** FLOAT SATINÉ, verre imprimé  
**CHÂSSIS** FU-RFKR-60/16  
**FERRURE** NEO, acier inoxydable mat

**MODELL** 6 STANDARD TB-LA3-DA  
**OBERFLÄCHE** CPL Seidengrau  
**GLAS** FLOAT SATINIERT, Ornamentglas  
**ZARGE** FU-RFKR-60/16  
**BESCHLAG** NEO, Edelstahl Matt  
**MODÈLE** PORTES STANDARD TB-LA3-DA  
**FINITION** CPL Gris soie  
**VERRE** FLOAT SATINÉ, verre imprimé  
**CHÂSSIS** FU-RFKR-60/16  
**FERRURE** NEO, acier inoxydable mat

**MODELL** 7 STANDARD TB-LA1-DA  
**OBERFLÄCHE** CPL Seidengrau  
**GLAS** FLOAT SATINIERT, Ornamentglas  
**ZARGE** FU-RFKR-60/16  
**BESCHLAG** NEO, Edelstahl Matt  
**MODÈLE** PORTES STANDARD TB-LA1-DA  
**FINITION** CPL Gris soie  
**VERRE** FLOAT SATINÉ, verre imprimé  
**CHÂSSIS** FU-RFKR-60/16  
**FERRURE** NEO, acier inoxydable mat

**MODELL** 8 STANDARD TB-DQ  
**OBERFLÄCHE** CPL Seidengrau  
**GLAS** -  
**ZARGE** FU-RFKR-60/16  
**BESCHLAG** NEO, Edelstahl Matt  
**MODÈLE** PORTES STANDARD TB-DQ  
**FINITION** CPL Gris soie  
**VERRE** -  
**CHÂSSIS** FU-RFKR-60/16  
**FERRURE** NEO, acier inoxydable mat

STANDARD  
CPL Karo White & Karo Beige

Einfach erstklassig  
L'excellence tout simplement

Ob als Drehtür oder Schiebetür, ob mit oder ohne Glas: Mit Karo White Türen inkl. Premiumkante beweisen Sie Sinn für Stil und Qualität. Que ce soit pour une porte pivotante ou coulissante, avec ou sans verre : avec les portes Karo White, y compris le chant Premium, vous optez pour le style et la qualité.

QUERSCHNITT | COUPE TRANSVERSALE

PREMIUMKANTE | CHANT PREMIUM

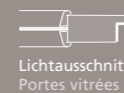

Lichtausschnitt-Türen  
Portes vitrées

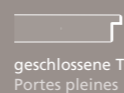

geschlossene Türen  
Portes pleines



BESCHLAG  
NOVO

GRAPHITSCHWARZ  
NOIR GRAPHITE



BB/RZ/WC



smart2lock

EDELSTAHL MATT  
ACIER INOXYDABLE MAT



BB/RZ/WC



smart2lock



**MODELL** 1 STANDARD TB-DA  
**OBERFLÄCHE** CPL Karo White  
**GLAS** -  
**ZARGE** FU-RFKR-60/16  
**BESCHLAG** NOVO, Graphitschwarz  
**MODÈLE** PORTES STANDARD TB-DA  
**FINITION** CPL Karo White  
**VERRE** -  
**CHÂSSIS** FU-RFKR-60/16  
**FERRURE** NOVO, noir graphite

**2** STANDARD TB-LA-DA+SP4  
CPL Karo White  
FLOAT SATINIERT, Ornamentglas  
FU-RFKR-60/16  
NOVO, Graphitschwarz  
PORTES STANDARD TB-LA-DA+SP4  
CPL Karo White  
FLOAT SATINÉ, verre imprimé  
FU-RFKR-60/16  
NOVO, noir graphite

**3** STANDARD TB-LA-DA  
CPL Karo White  
FLOAT SATINIERT, Ornamentglas  
FU-RFKR-60/16  
NOVO, Graphitschwarz  
PORTES STANDARD TB-LA-DA  
CPL Karo White  
FLOAT SATINÉ, verre imprimé  
FU-RFKR-60/16  
NOVO, noir graphite

**4** STANDARD TB-LA2-DA  
CPL Karo White  
FLOAT SATINIERT, Ornamentglas  
FU-RFKR-60/16  
NOVO, Graphitschwarz  
PORTES STANDARD TB-LA2-DA  
CPL Karo White  
FLOAT SATINÉ, verre imprimé  
FU-RFKR-60/16  
NOVO, noir graphite

**5** STANDARD TB-LA2S-DA  
CPL Karo Beige  
FLOAT SATINIERT, Ornamentglas  
FU-RFKR-60/16  
NOVO, Edelstahloptik Matt  
PORTES STANDARD TB-LA2S-DA  
CPL Karo Beige  
FLOAT SATINÉ, verre imprimé  
FU-RFKR-60/16  
NOVO, aspect inox mat

**6** STANDARD TB-LA3-DA  
CPL Karo Beige  
FLOAT SATINIERT, Ornamentglas  
FU-RFKR-60/16  
NOVO, Edelstahloptik Matt  
PORTES STANDARD TB-LA3-DA  
CPL Karo Beige  
FLOAT SATINÉ, verre imprimé  
FU-RFKR-60/16  
NOVO, aspect inox mat

**7** STANDARD TB-LA1-DA  
CPL Karo Beige  
FLOAT SATINIERT, Ornamentglas  
FU-RFKR-60/16  
NOVO, Edelstahloptik Matt  
PORTES STANDARD TB-LA1-DA  
CPL Karo Beige  
FLOAT SATINÉ, verre imprimé  
FU-RFKR-60/16  
NOVO, aspect inox mat

**8** STANDARD TB-DA  
CPL Karo Beige  
-  
FU-RFKR-60/16  
NOVO, Edelstahl Matt  
PORTES STANDARD TB-DA  
CPL Karo Beige  
-  
FU-RFKR-60/16  
NOVO, aspect inox mat



STANDARD  
CPL Karo Dark & Karo Grey

Perfekt puristisch  
Style épuré impeccable

Türen in dunklem Oberflächen-Ton und mit der neuen Premiumkante:  
Freuen Sie sich auf ausgezeichnetes Design mit vielen Mehrwerten.  
Des portes dans des tons sombres avec le nouveau chant Premium :  
laissez-vous séduire par un design remarquable avec de nombreuses  
valeurs ajoutées

QUERSCHNITT | COUPE TRANSVERSALE

PREMIUMKANTE | CHANT PREMIUM

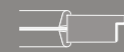

Lichtausschnitt-Türen  
Portes vitrées

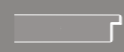

geschlossene Türen  
Portes pleines



PK2



PREMIUM  
KANTE

BESCHLAG  
MONO

GRAPHITSCHWARZ  
NOIR GRAPHITE

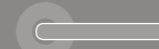

BB/RZ/WC



smart2lock

EDELSTAHL MATT  
ACIER INOXYDABLE MAT



BB/RZ/WC



smart2lock

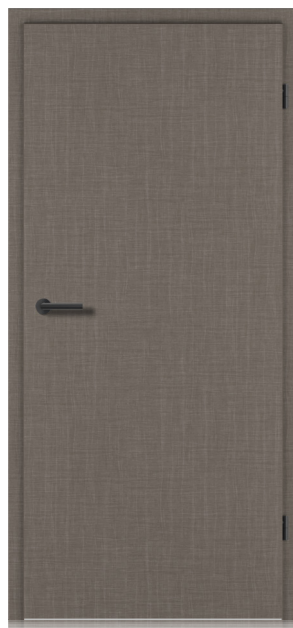

**1** STANDARD TB-DA  
CPL Karo Dark  
-  
FU-RFKR-60/16  
MONO, Graphitschwarz  
MODÈLE  
FINITION  
VERRE  
CHÂSSIS  
FERRURE



**2** STANDARD TB-LA-DA+SP4  
CPL Karo Dark  
FLOAT SATINIERT, Ornamentglas  
FU-RFKR-60/16  
MONO, Graphitschwarz  
PORTES STANDARD TB-LA-DA+SP4  
CPL Karo Dark  
FLOAT SATINÉ, verre imprimé  
FU-RFKR-60/16  
MONO, Noir graphite

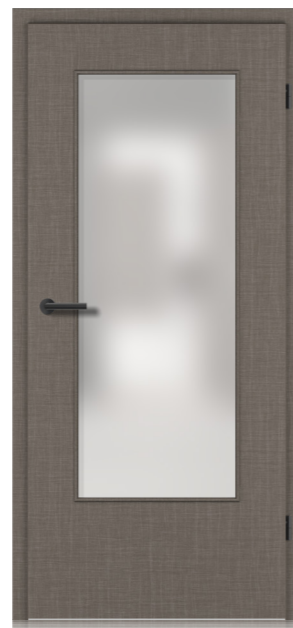

**3** STANDARD TB-LA-DA  
CPL Karo Dark  
FLOAT SATINIERT, Ornamentglas  
FU-RFKR-60/16  
MONO, Graphitschwarz  
PORTES STANDARD TB-LA-DA  
CPL Karo Dark  
FLOAT SATINÉ, verre imprimé  
FU-RFKR-60/16  
MONO, Noir graphite



**4** STANDARD TB-LA2-DA  
CPL Karo Dark  
FLOAT SATINIERT, Ornamentglas  
FU-RFKR-60/16  
MONO, Graphitschwarz  
PORTES STANDARD TB-LA2-DA  
CPL Karo Dark  
FLOAT SATINÉ, verre imprimé  
FU-RFKR-60/16  
MONO, Noir graphite



**5** STANDARD TB-LA2S-DA  
CPL Karo Grey  
FLOAT SATINIERT, Ornamentglas  
FU-RFKR-60/16  
MONO, Edeldstahl optik Matt  
PORTES STANDARD TB-LA2S-DA  
CPL Karo Grey  
FLOAT SATINÉ, verre imprimé  
FU-RFKR-60/16  
MONO, aspect inox mat



**6** STANDARD TB-LA3-DA  
CPL Karo Grey  
FLOAT SATINIERT, Ornamentglas  
FU-RFKR-60/16  
MONO, Edeldstahl optik Matt  
PORTES STANDARD TB-LA3-DA  
CPL Karo Grey  
FLOAT SATINÉ, verre imprimé  
FU-RFKR-60/16  
MONO, aspect inox mat



**7** STANDARD TB-LA1-DA  
CPL Karo Grey  
FLOAT SATINIERT, Ornamentglas  
FU-RFKR-60/16  
MONO, Edeldstahl optik Matt  
PORTES STANDARD TB-LA1-DA  
CPL Karo Grey  
FLOAT SATINÉ, verre imprimé  
FU-RFKR-60/16  
MONO, aspect inox mat



**8** STANDARD TB-DA  
CPL Karo Grey  
-  
FU-RFKR-60/16  
MONO, Edeldstahl Matt  
PORTES STANDARD TB-DA  
CPL Karo Grey  
-  
FU-RFKR-60/16  
MONO, aspect inox mat

STANDARD  
CPL Touch Darkline & Silvaline

Die neue Coolness für den zeitlos modernen Wohnstil.

Le nouveau style cool pour un intérieur moderne et intemporel.

Der trendige Türenlook mit edler, haptischer Oberfläche.  
Des portes tendance à la surface noble et haptique.

QUERSCHNITT | COUPE TRANSVERSALE

KLEINE RUNDKANTE | PETIT CHANT ARRONDI

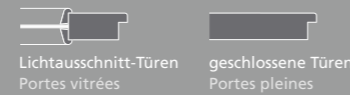

PREMIUMKANTE | CHANT PREMIUM

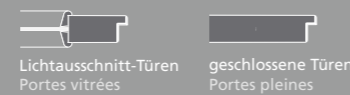

BESCHLAG  
MONO

GRAPHITSCHWARZ  
NOIR GRAPHITE



BB/RZ/WC



smart2lock

EDELSTAHL MATT  
ACIER INOXYDABLE MAT



BB/RZ/WC



smart2lock



**1** STANDARD TB-DA  
CPL Touch Darkline  
-  
FU-RF-60/16  
MONO, Graphitschwarz



**2** STANDARD TB-LA-DA+SP4  
CPL Touch Darkline  
FLOAT SATINIERT, Ornamentglas  
FU-RF-60/16  
MONO, Graphitschwarz



**3** STANDARD TB-LA-DA  
CPL Touch Darkline  
FLOAT SATINIERT, Ornamentglas  
FU-RF-60/16  
MONO, Graphitschwarz



**4** STANDARD TB-LA2-DA  
CPL Touch Darkline  
FLOAT SATINIERT, Ornamentglas  
FU-RF-60/16  
MONO, Graphitschwarz



**5** STANDARD TB-LA2S-DQ  
CPL Touch Silvaline  
FLOAT SATINIERT, Ornamentglas  
FU-RF-60/16  
MONO, Edelstahl Matt



**6** STANDARD TB-LA3-DQ  
CPL Touch Silvaline  
FLOAT SATINIERT, Ornamentglas  
FU-RF-60/16  
MONO, Edelstahl Matt



**7** STANDARD TB-LA1-DQ  
CPL Touch Silvaline  
FLOAT SATINIERT, Ornamentglas  
FU-RF-60/16  
MONO, Edelstahl Matt



**8** STANDARD TB-DQ  
CPL Touch Silvaline  
-  
FU-RFKR-60/16  
MONO, Edelstahl Matt

MODELL  
OBERFLÄCHE  
GLAS  
ZARGE  
BESCHLAG  
MODÈLE  
SURFACE  
VERRE  
CHÂSSIS  
FERRURE

PORTES STANDARD TB-DA  
CPL Touch Darkline  
-  
FU-RF-60/16  
MONO, noir graphite

PORTES STANDARD TB-LA-DA+SP4  
CPL Touch Darkline  
FLOAT SATINÉ, verre imprimé  
FU-RF-60/16  
MONO, noir graphite

PORTES STANDARD TB-LA-DA  
CPL Touch Darkline  
FLOAT SATINÉ, verre imprimé  
FU-RF-60/16  
MONO, noir graphite

PORTES STANDARD TB-LA2-DA  
CPL Touch Darkline  
FLOAT SATINÉ, verre imprimé  
FU-RF-60/16  
MONO, noir graphite

PORTES STANDARD TB-LA2S-DQ  
CPL Touch Silvaline  
FLOAT SATINÉ, verre imprimé  
FU-RF-60/16  
MONO, aspect inox mat

PORTES STANDARD TB-LA3-DQ  
CPL Touch Silvaline  
FLOAT SATINÉ, verre imprimé  
FU-RF-60/16  
MONO, aspect inox mat

PORTES STANDARD TB-LA1-DQ  
CPL Touch Silvaline  
FLOAT SATINÉ, verre imprimé  
FU-RF-60/16  
MONO, aspect inox mat

PORTES STANDARD TB-DQ  
CPL Touch Silvaline  
-  
FU-RFKR-60/16  
MONO, aspect inox mat

**STANDARD**  
**CPL Touch Pearlline**

Elegante Oberfläche in  
samtigem Perlmutter.

Surface élégante en  
nacre veloutée.

Von jung bis extravagant: Diese Türen beweisen überall Stil.  
De jeunes à extravagantes : ces portes font preuve de style partout.

**QUERSCHNITT | COUPE TRANSVERSALE**

**KLEINE RUNDKANTE | PETIT CHANT ARRONDI**

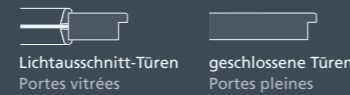

**PREMIUMKANTE | CHANT PREMIUM**

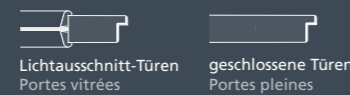

**BESCHLAG**  
**NEO**

GRAPHITSCHWARZ  
NOIR GRAPHITE



BB/RZ/WC



smart2lock

EDELSTAHL MATT  
ACIER INOXYDABLE MAT



BB/RZ/WC



smart2lock



**MODELL**  
**OBERFLÄCHE**  
**GLAS**  
**ZARGE**  
**BESCHLAG**  
**MODÈLE**  
**SURFACE**  
**VERRE**  
**CHÂSSIS**  
**FERRURE**

**1** STANDARD TB-DA  
CPL Touch Pearlline  
-  
FU-RFKR-60/16  
NEO, Graphitschwarz  
PORTES STANDARD TB-DA  
CPL Touch Pearlline  
-  
FU-RFKR-60/16  
NEO, noir graphite

**2** STANDARD TB-LA-DA+SP4  
CPL Touch Pearlline  
FLOAT SATINIERT, Ornamentglas  
FU-RFKR-60/16  
NEO, Graphitschwarz  
PORTES STANDARD TB-LA-DA+SP4  
CPL Touch Pearlline  
FLOAT SATINÉ, verre imprimé  
FU-RFKR-60/16  
NEO, noir graphite

**3** STANDARD TB-LA-DA  
CPL Touch Pearlline  
FLOAT SATINIERT, Ornamentglas  
FU-RFKR-60/16  
NEO, Graphitschwarz  
PORTES STANDARD TB-LA-DA  
CPL Touch Pearlline  
FLOAT SATINÉ, verre imprimé  
FU-RFKR-60/16  
NEO, noir graphite

**4** STANDARD TB-LA2-DA  
CPL Touch Pearlline  
FLOAT SATINIERT, Ornamentglas  
FU-RFKR-60/16  
NEO, Graphitschwarz  
PORTES STANDARD TB-LA2-DA  
CPL Touch Pearlline  
FLOAT SATINÉ, verre imprimé  
FU-RFKR-60/16  
NEO, noir graphite

**5** STANDARD TB-LA2S-DQ  
CPL Touch Pearlline  
FLOAT SATINIERT, Ornamentglas  
FU-RFKR-60/16  
NEO, Graphitschwarz  
PORTES STANDARD TB-LA2S-DQ  
CPL Touch Pearlline  
FLOAT SATINÉ, verre imprimé  
FU-RFKR-60/16  
NEO, aspect inox mat

**6** STANDARD TB-LA3-DQ  
CPL Touch Pearlline  
FLOAT SATINIERT, Ornamentglas  
FU-RFKR-60/16  
NEO, Graphitschwarz  
PORTES STANDARD TB-LA3-DQ  
CPL Touch Pearlline  
FLOAT SATINÉ, verre imprimé  
FU-RFKR-60/16  
NEO, aspect inox mat

**7** STANDARD TB-LA1-DQ  
CPL Touch Pearlline  
FLOAT SATINIERT, Ornamentglas  
FU-RFKR-60/16  
NEO, Graphitschwarz  
PORTES STANDARD TB-LA1-DQ  
CPL Touch Pearlline  
FLOAT SATINÉ, verre imprimé  
FU-RFKR-60/16  
NEO, aspect inox mat

**8** STANDARD TB-DQ  
CPL Touch Pearlline  
-  
FU-RFKR-60/16  
NEO, Edelstahl Matt  
PORTES STANDARD TB-DQ  
CPL Touch Pearlline  
-  
FU-RFKR-60/16  
NEO, aspect inox mat

**STANDARD**  
CPL Touch Greyline & Touch Whiteline

Berührend ästhetisch  
Touche esthétique

Eine klare Optik und helle Oberflächen bieten Raum für Visionen.  
Un aspect clair et des FINITIONS lumineuses pour un espace propice à l'élaboration de visions.

**QUERSCHNITT | COUPE TRANSVERSALE**

**KLEINE RUNDKANTE | PETIT CHANT ARRONDI**



**PREMIUMKANTE | CHANT PREMIUM**



**BESCHLAG**  
**NOVO**

GRAPHITSCHWARZ  
NOIR GRAPHITE



BB/RZ/WC



smart2lock

EDELSTAHL MATT  
ACIER INOXYDABLE MAT



BB/RZ/WC



smart2lock



**MODELL** 1 STANDARD TB-DA  
**OBERFLÄCHE** CPL Touch Greyline  
**GLAS** -  
**ZARGE** FU-RFKR-60/16  
**BESCHLAG** NOVO, Graphitschwarz  
**MODÈLE** PORTES STANDARD TB-DA  
**FINITION** CPL Touch Greyline  
**VERRE** -  
**CHÂSSIS** FU-RFKR-60/16  
**FERRURE** NOVO, noir graphite

**MODELL** 2 STANDARD TB-LA-DA+SP4  
**OBERFLÄCHE** CPL Touch Greyline  
**GLAS** FLOAT SATINIERT, Ornementglas  
**ZARGE** FU-RFKR-60/16  
**BESCHLAG** NOVO, Graphitschwarz  
**MODÈLE** PORTES STANDARD TB-LA-DA+SP4  
**FINITION** CPL Touch Greyline  
**VERRE** FLOAT SATINÉ, verre imprimé  
**CHÂSSIS** FU-RFKR-60/16  
**FERRURE** NOVO, noir graphite

**MODELL** 3 STANDARD TB-LA-DA  
**OBERFLÄCHE** CPL Touch Greyline  
**GLAS** FLOAT SATINIERT, Ornementglas  
**ZARGE** FU-RFKR-60/16  
**BESCHLAG** NOVO, Graphitschwarz  
**MODÈLE** PORTES STANDARD TB-LA-DA  
**FINITION** CPL Touch Greyline  
**VERRE** FLOAT SATINÉ, verre imprimé  
**CHÂSSIS** FU-RFKR-60/16  
**FERRURE** NOVO, noir graphite

**MODELL** 4 STANDARD TB-LA2-DA  
**OBERFLÄCHE** CPL Touch Greyline  
**GLAS** FLOAT SATINIERT, Ornementglas  
**ZARGE** FU-RFKR-60/16  
**BESCHLAG** NOVO, Graphitschwarz  
**MODÈLE** PORTES STANDARD TB-LA2-DA  
**FINITION** CPL Touch Greyline  
**VERRE** FLOAT SATINÉ, verre imprimé  
**CHÂSSIS** FU-RFKR-60/16  
**FERRURE** NOVO, noir graphite

**MODELL** 5 STANDARD TB-LA25-DQ  
**OBERFLÄCHE** CPL Touch Whiteline  
**GLAS** FLOAT SATINIERT, Ornementglas  
**ZARGE** FU-RFKR-60/16  
**BESCHLAG** NOVO, Edelstahl Matt  
**MODÈLE** PORTES STANDARD TB-LA25-DQ  
**FINITION** CPL Touch Whiteline  
**VERRE** FLOAT SATINÉ, verre imprimé  
**CHÂSSIS** FU-RFKR-60/16  
**FERRURE** NOVO, acier inoxydable mat

**MODELL** 6 STANDARD TB-LA3-DQ  
**OBERFLÄCHE** CPL Touch Whiteline  
**GLAS** FLOAT SATINIERT, Ornementglas  
**ZARGE** FU-RFKR-60/16  
**BESCHLAG** NOVO, Edelstahl Matt  
**MODÈLE** PORTES STANDARD TB-LA3-DQ  
**FINITION** CPL Touch Whiteline  
**VERRE** FLOAT SATINÉ, verre imprimé  
**CHÂSSIS** FU-RFKR-60/16  
**FERRURE** NOVO, acier inoxydable mat

**MODELL** 7 STANDARD TB-LA1-DQ  
**OBERFLÄCHE** CPL Touch Whiteline  
**GLAS** FLOAT SATINIERT, Ornementglas  
**ZARGE** FU-RFKR-60/16  
**BESCHLAG** NOVO, Edelstahl Matt  
**MODÈLE** PORTES STANDARD TB-LA1-DQ  
**FINITION** CPL Touch Whiteline  
**VERRE** FLOAT SATINÉ, verre imprimé  
**CHÂSSIS** FU-RFKR-60/16  
**FERRURE** NOVO, acier inoxydable mat

**MODELL** 8 STANDARD TB-DQ  
**OBERFLÄCHE** CPL Touch Whiteline  
**GLAS** -  
**ZARGE** FU-RF-60/16  
**BESCHLAG** NOVO, Edelstahl Matt  
**MODÈLE** PORTES STANDARD TB-DQ  
**FINITION** CPL Touch Whiteline  
**VERRE** -  
**CHÂSSIS** FU-RF-60/16  
**FERRURE** NOVO, acier inoxydable mat



**STANDARD**  
CPL Touch Wildeiche, Eiche Astig & Eiche Altholz

**Berührender Vintage-Look**  
Un look vintage plein d'émotion

**QUERSCHNITT WILDEICHE | COUPE TRANSVERSALE**

**KLEINE RUNDKANTE | PETIT CHANT ARRONDI**

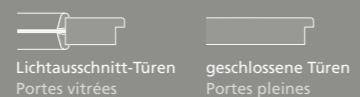

**PREMIUMKANTE | CHANT PREMIUM**



**QUERSCHNITT EICHE ASTIG/ALHOLZ | COUPE TRANSVERSALE**

**RUNDKANTE | CHANT ARRONDI**



**PREMIUMKANTE | CHANT PREMIUM**



**BESCHLAG**  
**NEO**

GRAPHITSCHWARZ  
NOIR GRAPHITE



BB/RZ/WC



smart2lock

EDELSTAHL MATT  
ACIER INOXYDABLE MAT



BB/RZ/WC



smart2lock

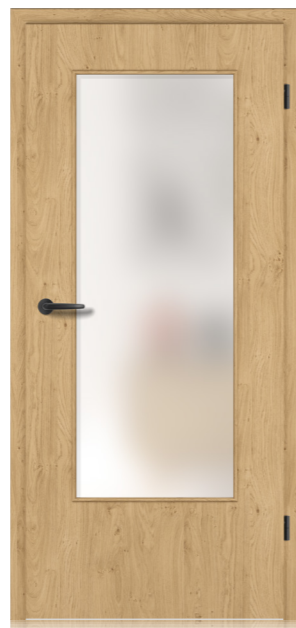

**MODELL**  
**OBERFLÄCHE**  
**GLAS**  
**ZARGE**  
**BESCHLAG**  
**MODÈLE**  
**FINITION**  
**VERRE**  
**CHÂSSIS**  
**FERRURE**

**1** STANDARD TB-DA  
CPL Touch Wildeiche  
-  
FU-RFKR-60/16  
NEO, Graphitschwarz  
PORTES STANDARD TB-DA  
CPL Touch Chêne sauvage  
-  
FU-RFKR-60/16  
NEO, noir graphite

**2** STANDARD TB-LA-DA+SP4  
CPL Touch Wildeiche  
FLOAT SATINIERT, Ornamentglas  
FU-RFKR-60/16  
NEO, Graphitschwarz  
PORTES STANDARD TB-LA-DA+SP4  
CPL Touch Chêne sauvage  
FLOAT SATINÉ, verre imprimé  
FU-RFKR-60/16  
NEO, noir graphite

**3** STANDARD TB-LA-DA  
CPL Touch Eiche Astig  
FLOAT SATINIERT, Ornamentglas  
FU-RFKR-60/16  
NEO, Graphitschwarz  
PORTES STANDARD TB-LA-DA  
CPL Touch chêne nouveau  
FLOAT SATINÉ, verre imprimé  
FU-RFKR-60/16  
NEO, noir graphite

**4** STANDARD TB-LA2-DA  
CPL Touch Eiche Astig  
FLOAT SATINIERT, Ornamentglas  
FU-RFKR-60/16  
NEO, Graphitschwarz  
PORTES STANDARD TB-LA2-DA  
CPL Touch chêne nouveau  
FLOAT SATINÉ, verre imprimé  
FU-RFKR-60/16  
NEO, noir graphite

**5** STANDARD TB-LA2S-DQ  
CPL Touch Eiche Astig  
FLOAT SATINIERT, Ornamentglas  
FU-RFKR-60/16  
NEO, Edeldahl matt  
PORTES STANDARD TB-LA2S-DQ  
CPL Touch chêne nouveau  
FLOAT SATINÉ, verre imprimé  
FU-RFKR-60/16  
NEO, acier inoxydable mat

**6** STANDARD TB-LA3-DQ  
CPL Touch Eiche Altholz  
FLOAT SATINIERT, Ornamentglas  
FU-RFKR-60/16  
NEO, Edeldahl matt  
PORTES STANDARD TB-LA3-DQ  
CPL Touch vieux chêne  
FLOAT SATINÉ, verre imprimé  
FU-RFKR-60/16  
NEO, acier inoxydable mat

**7** STANDARD TB-LA1-DQ  
CPL Touch Eiche Altholz  
FLOAT SATINIERT, Ornamentglas  
FU-RFKR-60/16  
NEO, Edeldahl matt  
PORTES STANDARD TB-LA1-DQ  
CPL Touch vieux chêne  
FLOAT SATINÉ, verre imprimé  
FU-RFKR-60/16  
NEO, acier inoxydable mat

**8** STANDARD TB-DQ  
CPL Touch Eiche Altholz  
-  
FU-RFKR-60/16  
NEO, Edeldahl matt  
PORTES STANDARD TB-DQ  
CPL Touch vieux chêne  
-  
FU-RFKR-60/16  
NEO, acier inoxydable mat

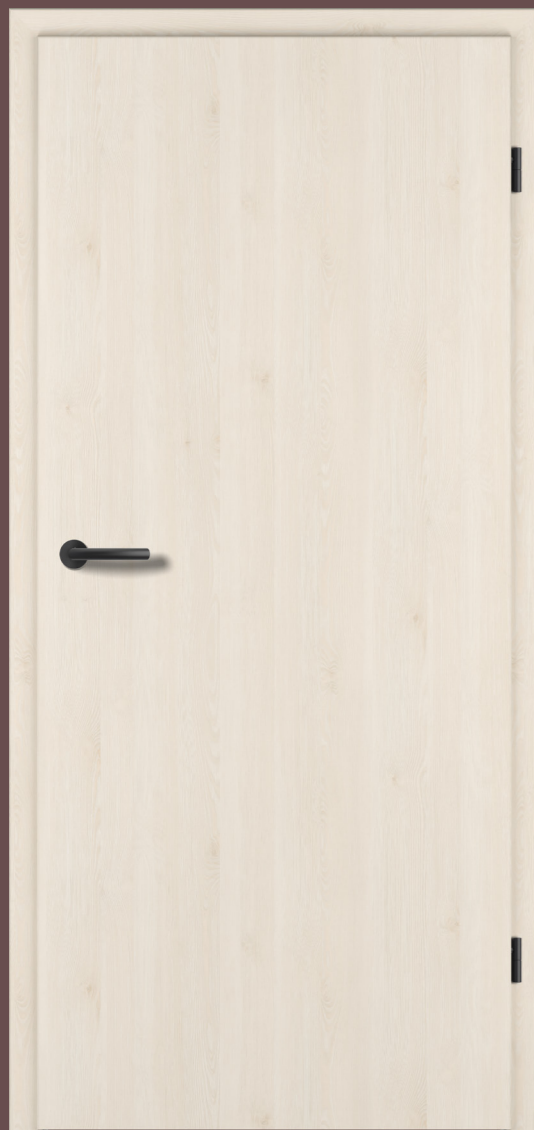

**STANDARD**  
CPL Touch Oak White, Creme & Nature

Ganz im Zeichen der Eiche  
Sous le signe du chêne

Unsere Oak-Oberflächen bieten ein verblüffend echtes Holzgefühl.  
Nos finitions Oak imitent l'apparence du bois à s'y méprendre.

**QUERSCHNITT | COUPE TRANSVERSALE**

**RUNDKANTE | CHANT ARRONDI**

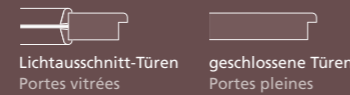

**PREMIUMKANTE | CHANT PREMIUM**

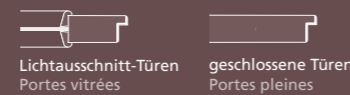

**BESCHLAG**  
**NOVO**

**GRAPHITSCHWARZ**  
NOIR GRAPHITE



BB/RZ/WC



smart2lock

**EDELSTAHL MATT**  
ACIER INOXYDABLE MAT



BB/RZ/WC



smart2lock

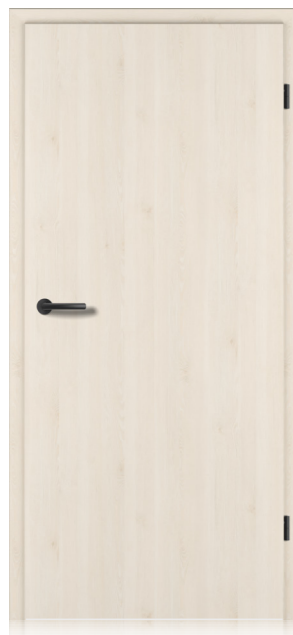

**MODELL**  
**OBERFLÄCHE**  
**GLAS**  
**ZARGE**  
**BESCHLAG**  
**MODÈLE**  
**FINITION**  
**VERRE**  
**CHÂSSIS**  
**FERRURE**

**1** STANDARD TB-DA  
CPL Touch Oak White  
-  
FU-RF-60/16  
NOVO, Graphitschwarz  
PORTES STANDARD TB-DA  
CPL Touch Oak White  
-  
FU-RF-60/16  
NOVO, noir graphite

**2** STANDARD TB-LA-DA+SP4  
CPL Touch Oak White  
FLOAT SATINIERT, Ornamentglas  
FU-RF-60/16  
NOVO, Graphitschwarz  
PORTES STANDARD TB-LA-DA+SP4  
CPL Touch Oak White  
FLOAT SATINÉ, verre imprimé  
FU-RF-60/16  
NOVO, noir graphite

**3** STANDARD TB-LA-DA  
CPL Touch Oak White  
FLOAT SATINIERT, Ornamentglas  
FU-RF-60/16  
NOVO, Graphitschwarz  
PORTES STANDARD TB-LA-DA  
CPL Touch Oak White  
FLOAT SATINÉ, verre imprimé  
FU-RF-60/16  
NOVO, noir graphite

**4** STANDARD TB-LA2-DA  
CPL Touch Oak Creme  
FLOAT SATINIERT, Ornamentglas  
FU-RF-60/16  
NOVO, Graphitschwarz  
PORTES STANDARD TB-LA2-DA  
CPL Touch Oak Creme  
FLOAT SATINÉ, verre imprimé  
FU-RF-60/16  
NOVO, noir graphite

**5** STANDARD TB-LA25-DQ  
CPL Touch Oak Creme  
FLOAT SATINIERT, Ornamentglas  
FU-RF-60/16  
NOVO, Edelstahl Matt  
PORTES STANDARD TB-LA25-DQ  
CPL Touch Oak Creme  
FLOAT SATINÉ, verre imprimé  
FU-RF-60/16  
NOVO, acier inoxydable mat

**6** STANDARD TB-LA3-DQ  
CPL Touch Oak Nature  
FLOAT SATINIERT, Ornamentglas  
FU-RF-60/16  
NOVO, Edelstahl Matt  
PORTES STANDARD TB-LA3-DQ  
CPL Touch Oak Nature  
FLOAT SATINÉ, verre imprimé  
FU-RF-60/16  
NOVO, acier inoxydable mat

**7** STANDARD TB-LA1-DQ  
CPL Touch Oak Nature  
FLOAT SATINIERT, Ornamentglas  
FU-RF-60/16  
NOVO, Edelstahl Matt  
PORTES STANDARD TB-LA1-DQ  
CPL Touch Oak Nature  
FLOAT SATINÉ, verre imprimé  
FU-RF-60/16  
NOVO, acier inoxydable mat

**8** STANDARD TB-DQ  
CPL Touch Oak Nature  
-  
FU-RF-60/16  
NOVO, Edelstahl Matt  
PORTES STANDARD TB-DQ  
CPL Touch Oak Nature  
-  
FU-RF-60/16  
NOVO, acier inoxydable mat



**STANDARD**  
CPL Touch Eiche & Touch Pinie

**Klassisch und innovativ**  
Classique et innovant

Die neue Interpretation einer klassischen Oberfläche setzt moderne Akzente.  
La nouvelle interprétation d'une finition classique pose des accents modernes.

**QUERSCHNITT | COUPE TRANSVERSALE**

**RUNDKANTE | CHANT ARRONDI**

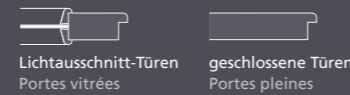

**PREMIUMKANTE | CHANT PREMIUM**

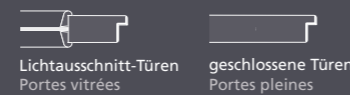

**BESCHLAG**  
**NEO**

GRAPHITSCHWARZ  
NOIR GRAPHITE



BB/RZ/WC



smart2lock

EDELSTAHL MATT  
ACIER INOXYDABLE MAT



BB/RZ/WC



smart2lock



**MODELL**  
**OBERFLÄCHE**  
**GLAS**  
**ZARGE**  
**BESCHLAG**  
**MODÈLE**  
**FINITION**  
**VERRE**  
**CHÂSSIS**  
**FERRURE**

**1** STANDARD TB-DA  
CPL Touch Eiche  
-  
FU-RF-60/16  
NEO, Graphitschwarz  
PORTES STANDARD TB-DA  
CPL Touch chêne  
-  
FU-RF-60/16  
NEO, noir graphite

**2** STANDARD TB-LA-DA+SP4  
CPL Touch Eiche  
FLOAT SATINIERT, Ornamentglas  
FU-RF-60/16  
NEO, Graphitschwarz  
PORTES STANDARD TB-LA-DA+SP4  
CPL Touch chêne  
FLOAT SATINÉ, verre imprimé  
FU-RF-60/16  
NEO, noir graphite

**3** STANDARD TB-LA-DA  
CPL Touch Eiche  
FLOAT SATINIERT, Ornamentglas  
FU-RF-60/16  
NEO, Graphitschwarz  
PORTES STANDARD TB-LA-DA  
CPL Touch chêne  
FLOAT SATINÉ, verre imprimé  
FU-RF-60/16  
NEO, noir graphite

**4** STANDARD TB-LA2-DA  
CPL Touch Eiche  
FLOAT SATINIERT, Ornamentglas  
FU-RF-60/16  
NEO, Graphitschwarz  
PORTES STANDARD TB-LA2-DA  
CPL Touch chêne  
FLOAT SATINÉ, verre imprimé  
FU-RF-60/16  
NEO, noir graphite

**5** STANDARD TB-LA2S-DQ  
CPL Touch Pinie  
FLOAT SATINIERT, Ornamentglas  
FU-RF-60/16  
NEO, Edelstahl Matt  
PORTES STANDARD TB-LA2S-DQ  
CPL Touch pinie  
FLOAT SATINÉ, verre imprimé  
FU-RF-60/16  
NEO, acier inoxydable mat

**6** STANDARD TB-LA3-DQ  
CPL Touch Pinie  
FLOAT SATINIERT, Ornamentglas  
FU-RF-60/16  
NEO, Edelstahl Matt  
PORTES STANDARD TB-LA3-DQ  
CPL Touch pinie  
FLOAT SATINÉ, verre imprimé  
FU-RF-60/16  
NEO, acier inoxydable mat

**7** STANDARD TB-LA1-DQ  
CPL Touch Pinie  
FLOAT SATINIERT, Ornamentglas  
FU-RF-60/16  
NEO, Edelstahl Matt  
PORTES STANDARD TB-LA1-DQ  
CPL Touch pinie  
FLOAT SATINÉ, verre imprimé  
FU-RF-60/16  
NEO, acier inoxydable mat

**8** STANDARD TB-DQ  
CPL Touch Pinie  
-  
FU-RF-60/16  
NEO, Edelstahl Matt  
PORTES STANDARD TB-DQ  
CPL Touch pinie  
-  
FU-RF-60/16  
NEO, acier inoxydable mat

**STANDARD**  
CPL Ahorn Pur & Buche Pur

Naturgetreu und edel  
Authenticité, clarté et élégance

Fasziniert durch eine cremefarbene und helle Farbgebung, die von einer zarten Maserung in hellem Beige durchzogen wird.  
Fascine par sa teinte claire de couleur crème, traversée par une délicate veinure beige clair.

**QUERSCHNITT | COUPE TRANSVERSALE**

**RUNDKANTE | CHANT ARRONDI**



Lichtausschnitt-Türen  
Portes vitrées



geschlossene Türen  
Portes pleines



**PREMIUMKANTE | CHANT PREMIUM**



Lichtausschnitt-Türen  
Portes vitrées



geschlossene Türen  
Portes pleines



**BESCHLAG**  
NOVO

GRAPHITSCHWARZ  
NOIR GRAPHITE



BB/RZ/WC



smart2lock

EDELSTAHL MATT  
ACIER INOXYDABLE MAT



BB/RZ/WC



smart2lock



**MODELL**  
**OBERFLÄCHE**  
**GLAS**  
**ZARGE**  
**BESCHLAG**  
**MODÈLE**  
**FINITION**  
**VERRE**  
**CHÂSSIS**  
**FERRURE**

**1** STANDARD TB-DA  
CPL Ahorn Pur  
-  
FU-RF-60/16  
NOVO, Graphitschwarz  
PORTES STANDARD TB-DA  
CPL Érable pur  
-  
FU-RF-60/16  
NOVO, noir graphite

**2** STANDARD TB-LA-DA+SP4  
CPL Ahorn Pur  
FLOAT SATINIERT, Ornamentglas  
FU-RF-60/16  
NOVO, Graphitschwarz  
PORTES STANDARD TB-LA-DA+SP4  
CPL Érable pur  
FLOAT SATINÉ, verre imprimé  
FU-RF-60/16  
NOVO, noir graphite

**3** STANDARD TB-LA-DA  
CPL Ahorn Pur  
FLOAT SATINIERT, Ornamentglas  
FU-RF-60/16  
NOVO, Graphitschwarz  
PORTES STANDARD TB-LA-DA  
CPL Érable pur  
FLOAT SATINÉ, verre imprimé  
FU-RF-60/16  
NOVO, noir graphite

**4** STANDARD TB-LA2-DA  
CPL Ahorn Pur  
FLOAT SATINIERT, Ornamentglas  
FU-RF-60/16  
NOVO, Graphitschwarz  
PORTES STANDARD TB-LA2-DA  
CPL Érable pur  
FLOAT SATINÉ, verre imprimé  
FU-RF-60/16  
NOVO, noir graphite

**5** STANDARD TB-LA2S-DA  
CPL Buche Pur  
FLOAT SATINIERT, Ornamentglas  
FU-RF-60/16  
NOVO, Edelstahl Matt  
PORTES STANDARD TB-LA2S-DA  
CPL Hêtre pur  
FLOAT SATINÉ, verre imprimé  
FU-RF-60/16  
NOVO, acier inoxydable mat

**6** STANDARD TB-LA3-DA  
CPL Buche Pur  
FLOAT SATINIERT, Ornamentglas  
FU-RF-60/16  
NOVO, Edelstahl Matt  
PORTES STANDARD TB-LA3-DA  
CPL Hêtre pur  
FLOAT SATINÉ, verre imprimé  
FU-RF-60/16  
NOVO, acier inoxydable mat

**7** STANDARD TB-LA1-DA  
CPL Buche Pur  
FLOAT SATINIERT, Ornamentglas  
FU-RF-60/16  
NOVO, Edelstahl Matt  
PORTES STANDARD TB-LA1-DA  
CPL Hêtre pur  
FLOAT SATINÉ, verre imprimé  
FU-RF-60/16  
NOVO, acier inoxydable mat

**8** STANDARD TB-DQ  
CPL Buche Pur  
-  
FU-RF-60/16  
NOVO, Edelstahl Matt  
PORTES STANDARD TB-DQ  
CPL Hêtre pur  
-  
FU-RF-60/16  
NOVO, acier inoxydable mat



# Oberflächen-Übersicht

## Aperçu des finitions



### PREMIUMKANTE (PK2)

Alle CPL-Oberflächen auch mit Premiumkante erhältlich

### CHANT PREMIUM (PK2)

Toutes les finitions CPL également disponibles avec chant premium

### CPL – die intelligente Oberfläche

Wo es hart auf hart geht, müssen Türen eine Menge einstecken, ohne dass man es ihnen gleich ansieht. Ob in der privaten Mietwohnung oder im gewerblichen Bereich – Sie können sicher sein, dass auf CPL auch die härteste Beanspruchung kaum Spuren hinterlässt. Schliesslich sind die neuen CPL-Oberflächen nicht nur erstaunlich kratz-, stoss- und abriebfest, sondern auch absolut schmutzunempfindlich und beständig gegen haushaltsübliche Reinigungsmittel. Unglaublich.

### CPL - la finition intelligente

Lorsqu'elles sont fortement sollicitées, les portes doivent faire preuve de résistance et ne rien en laisser paraître. Que ce soit dans un appartement de location privé ou dans un espace commercial, vous avez l'assurance que même les sollicitations les plus rudes ne laisseront guère de traces sur le CPL. Enfin, les nouvelles finitions CPL sont non seulement étonnamment résistantes aux rayures, aux chocs et à l'abrasion, mais aussi absolument insensibles à la saleté et résistantes aux produits de nettoyage ménagers courants. Incroyable.



CPL KARO WHITE  
CPL CARREAU BLANC

CPL KARO BEIGE  
CPL CARREAU BEIGE

CPL KARO GREY  
CPL CARREAU GRIS

CPL KARO DARK  
CPL CARREAU FONCÉ

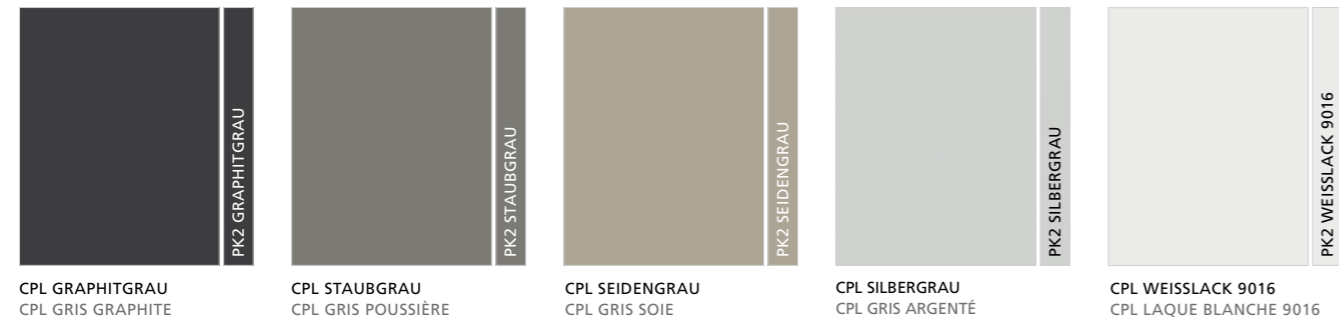

CPL GRAPHITGRAU  
CPL GRIS GRAPHITE

CPL STAUBGRAU  
CPL GRIS POUSSIÈRE

CPL SEIDENGRAU  
CPL GRIS SOIE

CPL SILBERGRAU  
CPL GRIS ARGENTÉ

CPL WEISSLACK 9016  
CPL LAQUE BLANCHE 9016



CPL AHORN PUR  
CPL ÉRABLE PUR

CPL BUCHE PUR  
CPL HÊTRE PUR

CPL EICHE  
CPL CHÊNE

CPL ESCHWEISS  
CPL FRÊNE BLANC

CPL WEISSLACK 9010  
CPL LAQUE BLANCHE 9010

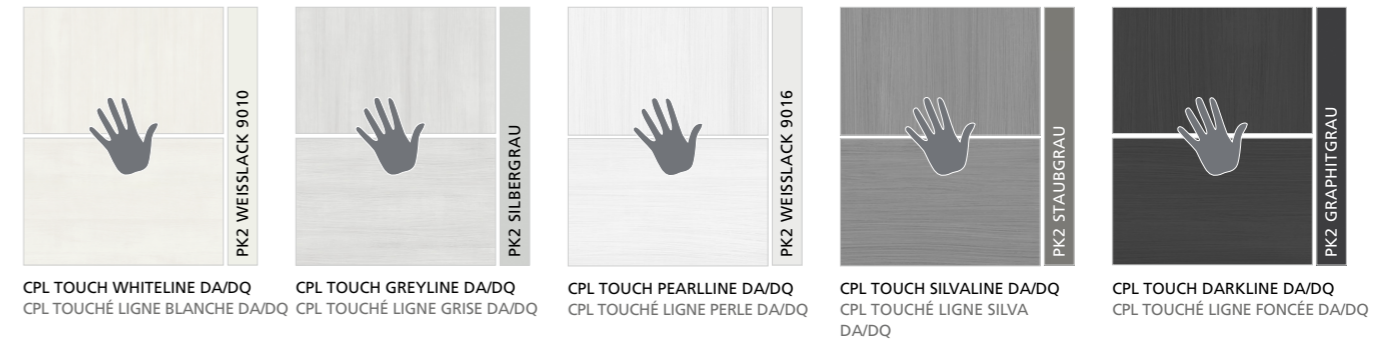

CPL TOUCH WHITELINE DA/DQ  
CPL TOUCHÉ LIGNE BLANCHE DA/DQ

CPL TOUCH GREYLINE DA/DQ  
CPL TOUCHÉ LIGNE GRISE DA/DQ

CPL TOUCH PEARLLINE DA/DQ  
CPL TOUCHÉ LIGNE PERLE DA/DQ

CPL TOUCH SILVALINE DA/DQ  
CPL TOUCHÉ LIGNE SILVA DA/DQ

CPL TOUCH DARKLINE DA/DQ  
CPL TOUCHÉ LIGNE FONCÉE DA/DQ

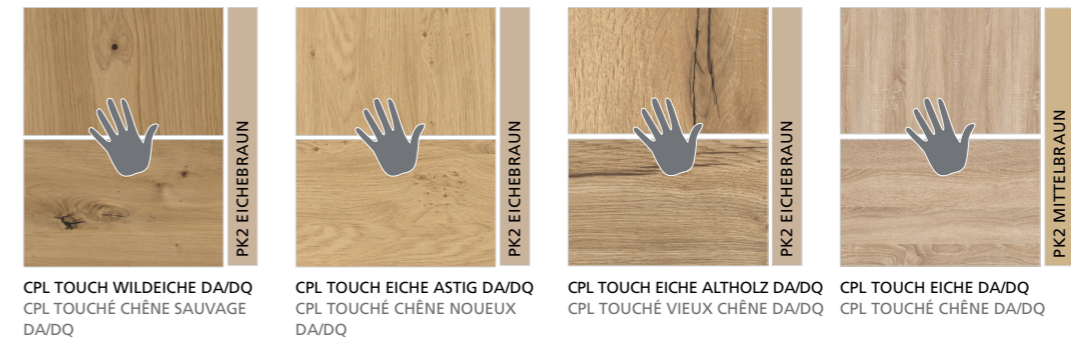

CPL TOUCH WILDEICHE DA/DQ  
CPL TOUCHÉ CHÊNE SAUVAGE DA/DQ

CPL TOUCH EICHE ASTIG DA/DQ  
CPL TOUCHÉ CHÊNE NOUVEUX DA/DQ

CPL TOUCH EICHE ALTHOLZ DA/DQ  
CPL TOUCHÉ VIEUX CHÊNE DA/DQ

CPL TOUCH EICHE DA/DQ  
CPL TOUCHÉ CHÊNE DA/DQ

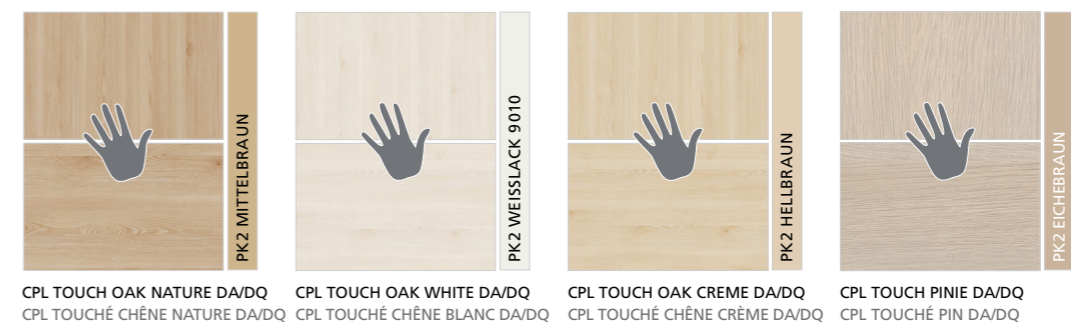

CPL TOUCH OAK NATURE DA/DQ  
CPL TOUCHÉ CHÊNE NATURE DA/DQ

CPL TOUCH OAK WHITE DA/DQ  
CPL TOUCHÉ CHÊNE BLANC DA/DQ

CPL TOUCH OAK CREME DA/DQ  
CPL TOUCHÉ CHÊNE CRÈME DA/DQ

CPL TOUCH PINIE DA/DQ  
CPL TOUCHÉ PIN DA/DQ



#### KEINE FINGERABDRÜCKE AUF DER OBERFLÄCHE!

Diese hochwertigen Oberflächen haben Antifingerprint-Eigenschaften.

#### DES SURFACES SANS AUCUNE TRACE DE DOIGT!

Ces surfaces haute qualité ont été traitées pour éviter les traces de doigts.



#### UNSERE NEUEN TOUCH-OBERFLÄCHEN KÖNNEN SIE AUCH FÜHLEN!

Sieht aus wie Furnier, fühlt sich an wie Echtholz und ist dabei besonders robust, farbecht und pflegeleicht!

#### VOUS POUVEZ MAINTENANT SENTIR NOS NOUVELLES SURFACES TOUCH!

On dirait du placage, mais elles ressemblent à du vrai bois, ce qui les rend particulièrement robustes. Leurs couleurs sont résistantes et elles sont faciles à entretenir.

# Gesamtübersicht CPL-Programm

## Vue d'ensemble de la gamme CPL

● Glasleisten in Edelstahl-Optik als Zusatzleistung erhältlich  
Baguettes à verre en aspect inox disponibles comme prestation supplémentaire

STANDARD | STANDARD

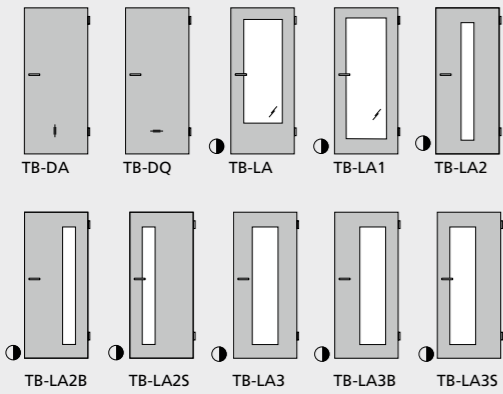

OBERFLÄCHEN  
FINITIONS



TÜRKANTEN  
CHANTS



OBERFLÄCHEN  
FINITIONS



TÜRKANTEN  
CHANTS

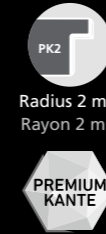

OBERFLÄCHEN  
FINITIONS



TÜRKANTEN  
CHANTS



GLÄSER | VERRES

### MODERNE ORNAMENTGLÄSER | VERRES IMPRIMÉS MODERNES

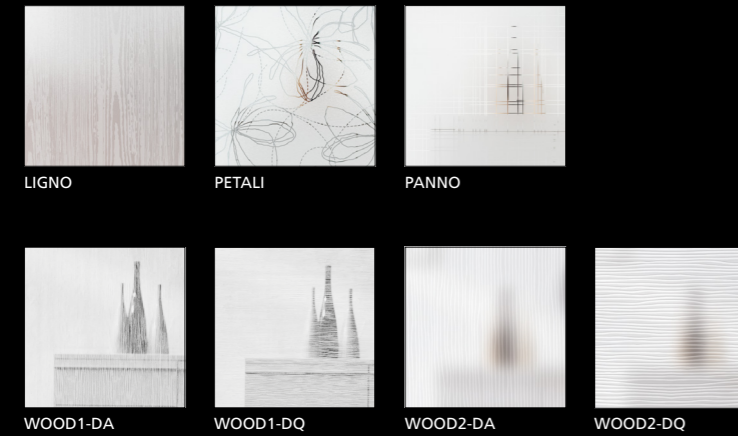

### KLASSISCHE ORNAMENTGLÄSER | VERRES IMPRIMÉS CLASSIQUES



\*Nicht als Ganzglastür oder LA4, LA5 erhältlich  
\*Non disponibles pour les portes tout-verre ou LA4, LA5

TOP-BESCHLÄGE | FERRURES TOP

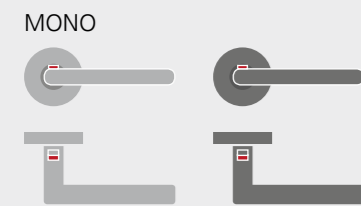

WÄHLBAR IN EDELSTAHL MATT ODER GRAPHITSCHWARZ  
DISPONIBLE EN ACIER INOXYDABLE MAT OU NOIR GRAPHITE

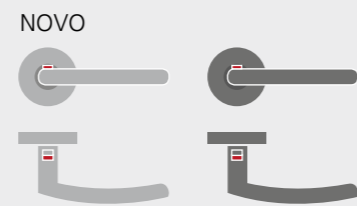

WÄHLBAR IN EDELSTAHL MATT ODER GRAPHITSCHWARZ  
DISPONIBLE EN ACIER INOXYDABLE MAT OU NOIR GRAPHITE

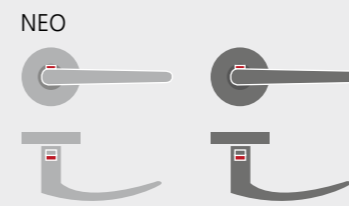

WÄHLBAR IN EDELSTAHL MATT ODER GRAPHITSCHWARZ  
DISPONIBLE EN ACIER INOXYDABLE MAT OU NOIR GRAPHITE



## Weisslack-Programm | Gamme Blanc laqué

Darstellung Weisslack 9016, Bänder V7888 | Représentation Blanc laqué 9016, paumelles V7888

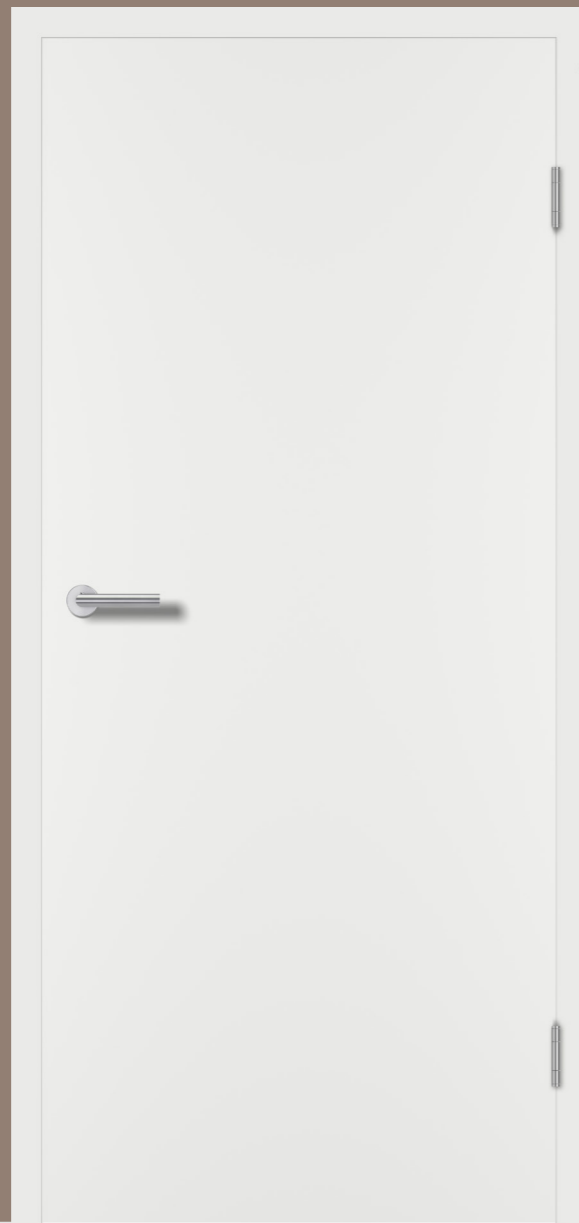

Türen, für die man sich immer wieder entscheiden würde: Einfach schön – und mit einer grossen Auswahl an interessanten Oberflächen und Details.

Ces portes sont une valeur sûre : en plus d'être belles, elles proposent un grand choix de finitions et de détails intéressants.



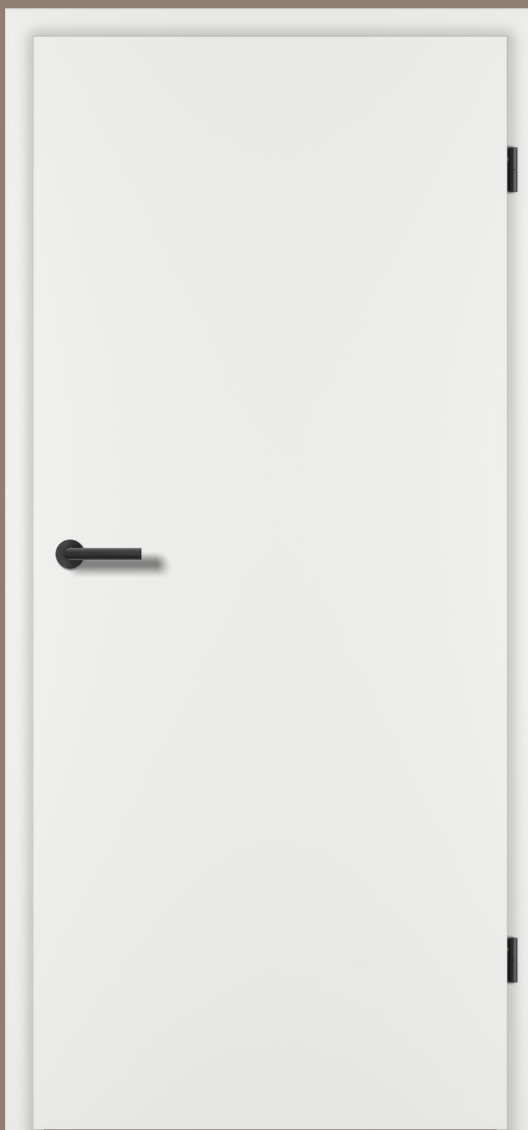

## STANDARD Weisslack 9016/9010

### Die perfekte Basis für Wohnlichkeit

La base idéale  
du confort

#### QUERSCHNITT 9016 | COUPE TRANSVERSALE 9016

KLEINE RUNDKANTE | PETIT CHANT ARRONDI

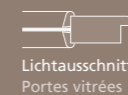

Lichtausschnitt-Türen  
Portes vitrées

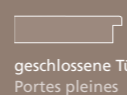

geschlossene Türen  
Portes pleines



RPKR



#### QUERSCHNITT 9010 | COUPE TRANSVERSALE 9010

RUNDKANTE | CHANT ARRONDI

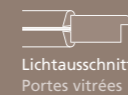

Lichtausschnitt-Türen  
Portes vitrées

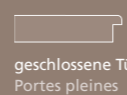

geschlossene Türen  
Portes pleines



RP



ECKIGE KANTE | CHANT DROIT

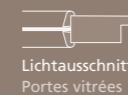

Lichtausschnitt-Türen  
Portes vitrées

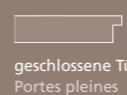

geschlossene Türen  
Portes pleines



EC



## BESCHLAG MONO

GRAPHITSCHWARZ  
NOIR GRAPHITE



BB/RZ/WC



smart2lock

EDELSTAHL MATT  
ACIER INOXYDABLE MAT



BB/RZ/WC



smart2lock



**1** STANDARD TB-WL  
Weisslack 9016  
-  
FU-RFKR-60/16  
MONO, Graphitschwarz  
MODÈLE  
FINITION  
VERRE  
CHÂSSIS  
FERRURE

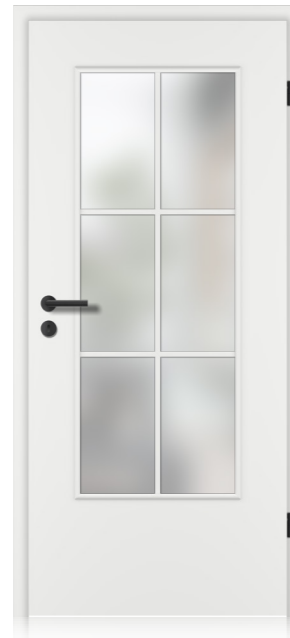

**2** STANDARD TB-LA-WL+SP4  
Weisslack 9016  
FLOAT SATINIERT, Ornamentglas  
FU-RFKR-60/16  
MONO, Graphitschwarz  
PORTES STANDARD TB-LA-WL+SP4  
Blanc laqué 9016  
FLOAT SATINÉ, verre imprimé  
FU-RFKR-60/16  
MONO, noir graphite

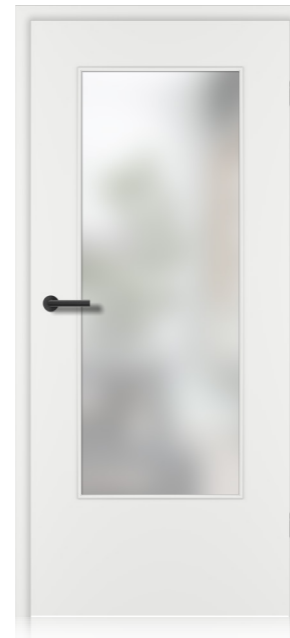

**3** STANDARD TB-LA-WL  
Weisslack 9016  
FLOAT SATINIERT, Ornamentglas  
FU-RFKR-60/16  
MONO, Graphitschwarz  
PORTES STANDARD TB-LA-WL  
Blanc laqué 9016  
FLOAT SATINÉ, verre imprimé  
FU-RFKR-60/16  
MONO, noir graphite



**4** STANDARD TB-LA2-WL+SP20  
Weisslack 9016  
FLOAT SATINIERT, Ornamentglas  
FU-RFKR-60/16  
MONO, Graphitschwarz  
PORTES STANDARD TB-LA2-WL+SP20  
Blanc laqué 9016  
FLOAT SATINÉ, verre imprimé  
FU-RFKR-60/16  
MONO, noir graphite



**5** STANDARD TB-LA2S-WL  
Weisslack 9010  
FLOAT SATINIERT, Ornamentglas  
FU-RF-60/16  
MONO, Edelstahl Matt  
PORTES STANDARD TB-LA2S-WL  
Blanc laqué 9010  
FLOAT SATINÉ, verre imprimé  
FU-RF-60/16  
MONO, acier inoxydable mat

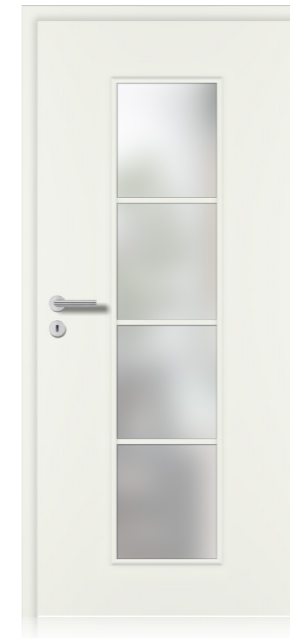

**6** STANDARD TB-LA3-WL+SP30  
Weisslack 9010  
FLOAT SATINIERT, Ornamentglas  
FU-RF-60/16  
MONO, Edelstahl Matt  
PORTES STANDARD TB-LA3-WL+SP30  
Blanc laqué 9010  
FLOAT SATINÉ, verre imprimé  
FU-RF-60/16  
MONO, acier inoxydable mat



**7** STANDARD TB-LA1-WL  
Weisslack 9010  
FLOAT SATINIERT, Ornamentglas  
FU-RF-60/16  
MONO, Edelstahl Matt  
PORTES STANDARD TB-LA1-WL  
Blanc laqué 9010  
FLOAT SATINÉ, verre imprimé  
FU-RF-60/16  
MONO, acier inoxydable mat



**8** STANDARD TB-WL  
Weisslack 9010  
-  
FU-RF-60/16  
MONO, Edelstahl Matt  
PORTES STANDARD TB-WL  
Blanc laqué 9010  
-  
FU-RF-60/16  
MONO, acier inoxydable mat



STANDARD  
Weisslack Exklusiv 9016/9010

So schön kann Weiss sein  
Toute la beauté du blanc

QUERSCHNITT 9016 | COUPE TRANSVERSALE 9016

KLEINE RUNDKANTE | PETIT CHANT ARRONDI



Lichtausschnitt-Türen  
Portes vitrées

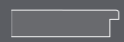

geschlossene Türen  
Portes pleines



QUERSCHNITT 9010 | COUPE TRANSVERSALE 9010

RUNDKANTE | CHANT ARRONDI



Lichtausschnitt-Türen  
Portes vitrées

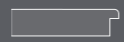

geschlossene Türen  
Portes pleines



ECKIGE KANTE | CHANT DROIT



Lichtausschnitt-Türen  
Portes vitrées

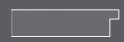

geschlossene Türen  
Portes pleines



BESCHLAG  
NOVO

GRAPHITSCHWARZ  
NOIR GRAPHITE



BB/RZ/WC



smart2lock

EDELSTAHL MATT  
ACIER INOXYDABLE MAT



BB/RZ/WC



smart2lock



**1** STANDARD TB-WL  
Weisslack Exklusiv 9016  
-  
FU-RFKR 60/16  
NOVO, Graphitschwarz  
PORTES STANDARD TB-WL  
Blanc laqué exclusif 9010  
-  
FU-RFKR 60/16  
NOVO, noir graphite



**2** STANDARD TB-LA-WL+SP4  
Weisslack Exklusiv 9016  
FLOAT SATINIERT, Ornamentglas  
FU-RFKR 60/16  
NOVO, Graphitschwarz  
PORTES STANDARD TB-LA-WL+SP4  
Blanc laqué exclusif 9010  
FLOAT SATINÉ, verre imprimé  
FU-RFKR 60/16  
NOVO, noir graphite

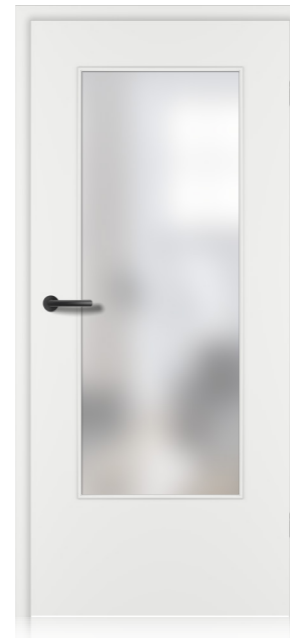

**3** STANDARD TB-LA-WL  
Weisslack Exklusiv 9016  
FLOAT SATINIERT, Ornamentglas  
FU-RFKR 60/16  
NOVO, Graphitschwarz  
PORTES STANDARD TB-LA-WL  
Blanc laqué exclusif 9010  
FLOAT SATINÉ, verre imprimé  
FU-RFKR 60/16  
NOVO, noir graphite



**4** STANDARD TB-LA2-WL+SP20  
Weisslack Exklusiv 9016  
FLOAT SATINIERT, Ornamentglas  
FU-RFKR 60/16  
NOVO, Graphitschwarz  
PORTES STANDARD TB-LA2-WL+SP20  
Blanc laqué exclusif 9010  
FLOAT SATINÉ, verre imprimé  
FU-RFKR 60/16  
NOVO, noir graphite



**5** STANDARD TB-LA25-WL  
Weisslack Exklusiv 9010  
FLOAT SATINIERT, Ornamentglas  
FU-RF-60/16  
NOVO, Edelstahl Matt  
PORTES STANDARD TB-LA25-WL  
Blanc laqué exclusif 9010  
FLOAT SATINÉ, verre imprimé  
FU-RF-60/16  
NOVO, acier inoxydable mat

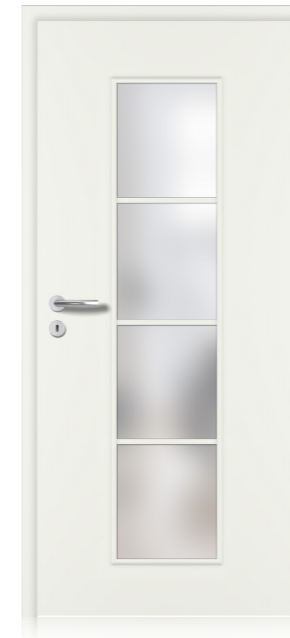

**6** STANDARD TB-LA3-WL+SP30  
Weisslack Exklusiv 9010  
FLOAT SATINIERT, Ornamentglas  
FU-RF-60/16  
NOVO, Edelstahl Matt  
PORTES STANDARD TB-LA3-WL+SP30  
Blanc laqué exclusif 9010  
FLOAT SATINÉ, verre imprimé  
FU-RF-60/16  
NOVO, acier inoxydable mat

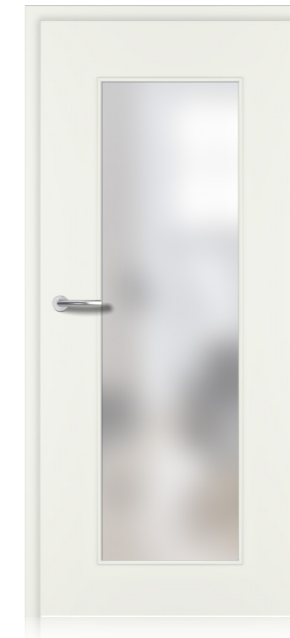

**7** STANDARD TB-LA1-WL  
Weisslack Exklusiv 9010  
FLOAT SATINIERT, Ornamentglas  
FU-RF-60/16  
NOVO, Edelstahl Matt  
PORTES STANDARD TB-LA1-WL  
Blanc laqué exclusif 9010  
FLOAT SATINÉ, verre imprimé  
FU-RF-60/16  
NOVO, acier inoxydable mat



**8** STANDARD TB-WL  
Weisslack Exklusiv 9010  
-  
FU-RF-60/16  
NOVO, Edelstahl Matt  
PORTES STANDARD TB-WL  
Blanc laqué exclusif 9010  
-  
FU-RF-60/16  
NOVO, acier inoxydable mat



**PRIMO**  
Weisslack Exklusiv 9016/9010

Ein visuelles Gedicht  
Véritable poème pour les yeux

Aussergewöhnliche Räume brauchen aussergewöhnliche Türen.  
Des portes exceptionnelles pour des pièces exceptionnelles.

**BESCHLAG**  
NOVO

GRAPHITSCHWARZ  
NOIR GRAPHITE



BB/RZ/WC



smart2lock

**QUERSCHNITT 9016 | COUPE TRANSVERSALE 9016**

RUNDKANTENPOSTFORMING KLEINE RUNDKANTE  
CHANT ARRONDI POSTFORMANT PETIT CHANT ARRONDI



Lichtausschnitt-Türen  
Portes vitrées



geschlossene Türen  
Portes pleines



**QUERSCHNITT 9010 | COUPE TRANSVERSALE 9010**

ECKIGE KANTE | CHANT DROIT



Lichtausschnitt-Türen  
Portes vitrées



geschlossene Türen  
Portes pleines



EDELSTAHL MATT  
ACIER INOXYDABLE MAT



BB/RZ/WC



smart2lock



**MODELL**  
**OBERFLÄCHE**  
**GLAS**  
**ZARGE**  
**BESCHLAG**  
**MODÈLE**  
**FINITION**  
**VERRE**  
**CHÂSSIS**  
**FERRURE**

**1** PRIMO PM2  
Weisslack Exklusiv 9016  
-  
FU-PRIMO-100/25  
NOVO, Graphitschwarz  
PRIMO PM2  
Blanc laqué exclusif 9016  
-  
FU-PRIMO-100/25  
NOVO, noir graphite

**2** PRIMO PML2/1  
Weisslack Exklusiv 9016  
FLOAT SATINIERT, Ornamentglas  
FU-PRIMO-100/25  
NOVO, Graphitschwarz  
PRIMO PML2/1  
Blanc laqué exclusif 9016  
FLOAT SATINÉ, verre imprimé  
FU-PRIMO-100/25  
NOVO, noir graphite

**3** PRIMO PM1  
Weisslack Exklusiv 9016  
-  
FU-PRIMO-100/25  
NOVO, Graphitschwarz  
PRIMO PM1  
Blanc laqué exclusif 9016  
-  
FU-PRIMO-100/25  
NOVO, noir graphite

**2** PRIMO PML1  
Weisslack Exklusiv 9016  
FLOAT SATINIERT, Ornamentglas  
FU-PRIMO-100/25  
NOVO, Graphitschwarz  
PRIMO PML1  
Blanc laqué exclusif 9016  
FLOAT SATINÉ, verre imprimé  
FU-PRIMO-100/25  
NOVO, noir graphite

**5** PRIMO PM3  
Weisslack Exklusiv 9010  
-  
FU-PRIMO-100/25  
NOVO, Edelstahl Matt  
PRIMO PM3  
Blanc laqué exclusif 9010  
-  
FU-PRIMO-100/25  
NOVO, acier inoxydable mat

**6** PRIMO PML3  
Weisslack Exklusiv 9010  
FLOAT SATINIERT, Ornamentglas  
FU-PRIMO-100/25  
NOVO, Edelstahl Matt  
PRIMO PML3  
Blanc laqué exclusif 9010  
FLOAT SATINÉ, verre imprimé  
FU-PRIMO-100/25  
NOVO, acier inoxydable mat

**7** PRIMO PM4/1  
Weisslack Exklusiv 9010  
-  
FU-PRIMO-100/25  
NOVO, Edelstahl Matt  
PRIMO PM4/1  
Blanc laqué exclusif 9010  
-  
FU-PRIMO-100/25  
NOVO, acier inoxydable mat

**8** PRIMO PML4/1  
Weisslack Exklusiv 9010  
-  
FU-PRIMO-100/25  
NOVO, Edelstahl Matt  
PRIMO PML4/1  
Blanc laqué exclusif 9010  
-  
FU-PRIMO-100/25  
NOVO, acier inoxydable mat

**MODENA**  
Weisslack Exklusiv 9016/9010

Leichtigkeit trifft Eleganz  
Quand la légèreté rencontre l'élégance

Eine Optik mit Mehrwert  
Une esthétique à haute valeur ajoutée

**QUERSCHNITT 9016 | COUPE TRANSVERSALE 9016**

RUNDKANTENPOSTFORMING KLEINE RUNDKANTE  
CHANT ARRONDI POSTFORMANT PETIT CHANT ARRONDI

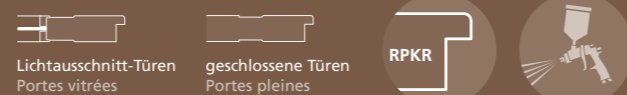

**QUERSCHNITT 9010 | COUPE TRANSVERSALE 9010**

ECKIGE KANTE | CHANT DROIT

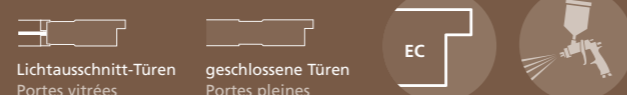

**BESCHLAG**  
**MONO**

GRAPHITSCHWARZ  
NOIR GRAPHITE



BB/RZ/WC



smart2lock

EDELSTAHL MATT  
ACIER INOXYDABLE MAT



BB/RZ/WC



smart2lock



Darstellung Weisslack 9016 | Représentation Blanc laqué 9016



MODELL OBERFLÄCHE GLAS ZARGE BESCHLAG MODÈLE FINITION VERRE CHÂSSIS FERRURE	1	2	3	4	5	6	7	8
	MODENA M1 Weisslack Exklusiv 9016	MODENA ML1 Weisslack Exklusiv 9016	MODENA M2 Weisslack Exklusiv 9016	MODENA ML2 Weisslack Exklusiv 9016	MODENA M3 Weisslack Exklusiv 9010	MODENA ML3 Weisslack Exklusiv 9010	MODENA ML2/1 Weisslack Exklusiv 9010	MODENA M2/1 Weisslack Exklusiv 9010
	-	FLOAT SATINIERT, Ornamentglas	-	FLOAT SATINIERT, Ornamentglas	-	FLOAT SATINIERT, Ornamentglas	FLOAT SATINIERT, Ornamentglas	-
	FU-RFKR-80/22	FU-RFKR-80/22	FU-RFKR-80/22	FU-RFKR-80/22	FU-EC-80/22	FU-EC-80/22	FU-EC-80/22	FU-EC-80/22
	MONO, Graphitschwarz	MONO, Graphitschwarz	MONO, Graphitschwarz	MONO, Graphitschwarz	MONO, Edelstahl Matt	MONO, Edelstahl Matt	MONO, Edelstahl Matt	MONO, Edelstahl Matt
	MODENA M1	MODENA ML1	MODENA M2	MODENA ML2	MODENA M3	MODENA ML3	MODENA ML2/1	MODENA M2/1
	Blanc laqué exclusif 9016	Blanc laqué exclusif 9016	Blanc laqué exclusif 9016	Blanc laqué exclusif 9016	Blanc laqué exclusif 9010	Blanc laqué exclusif 9010	Blanc laqué exclusif 9010	Blanc laqué exclusif 9010
	-	FLOAT SATINÉ, verre imprimé	-	FLOAT SATINÉ, verre imprimé	-	FLOAT SATINÉ, Verre imprimé	FLOAT SATINÉ, verre imprimé	-
	FU-RFKR-80/22	FU-RFKR-80/22	FU-RFKR-80/22	FU-RFKR-80/22	FU-EC-80/22	FU-EC-80/22	FU-EC-80/22	FU-EC-80/22
	MONO, noir graphite	MONO, noir graphite	MONO, noir graphite	MONO, noir graphite	MONO, acier inoxydable mat	MONO, acier inoxydable mat	MONO, acier inoxydable mat	MONO, acier inoxydable mat

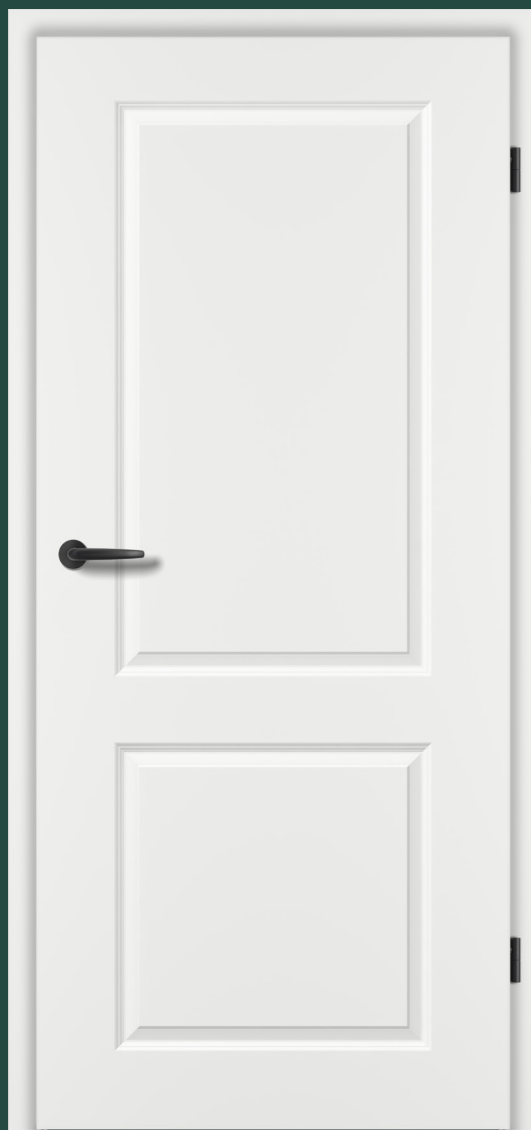

CLASSIC  
Weisslack Exklusiv 9016/9010

Klassische Eleganz  
Élégance classique

QUERSCHNITT 9016 | COUPE TRANSVERSALE 9016

RUNDKANTE KLEINE RUNDKANTE  
CHANT ARRONDI PETIT CHANT ARRONDI

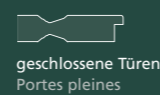

QUERSCHNITT 9010 | COUPE TRANSVERSALE 9010

RUNDKANTE | CHANT ARRONDI

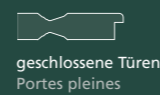

KARNIESKANTE | CHANT MOULURÉ

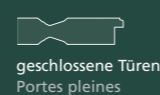

BESCHLAG  
NEO

GRAPHITSCHWARZ  
NOIR GRAPHITE



BB/RZ/WC



smart2lock

EDELSTAHL MATT  
ACIER INOXYDABLE MAT



BB/RZ/WC



smart2lock



**1** CLASSIC C2  
Weisslack Exklusiv 9016  
-  
FU-RFKR-60/16  
NEO, Graphitschwarz  
CLASSIC C2  
Blanc laqué exclusif 9016  
-  
FU-RFKR-60/16  
NEO, noir graphite



**2** CLASSIC CL2  
Weisslack Exklusiv 9016  
FLOAT SATINIERT, Ornamentglas  
FU-RFKR-60/16  
NEO, Graphitschwarz  
CLASSIC CL2  
Blanc laqué exclusif 9016  
FLOAT SATINÉ, verre imprimé  
FU-RFKR-60/16  
NEO, noir graphite



**3** CLASSIC CL2+SP4  
Weisslack Exklusiv 9016  
FLOAT SATINIERT, Ornamentglas  
FU-RFKR-60/16  
NEO, Graphitschwarz  
CLASSIC CL2+SP4  
Blanc laqué exclusif 9016  
FLOAT SATINÉ, verre imprimé  
FU-RFKR-60/16  
NEO, noir graphite



**4** CLASSIC C2  
Weisslack Exklusiv 9010  
-  
FU-RF-60/16  
NEO, Edelstahl Matt  
CLASSIC C2  
Blanc laqué exclusif 9010  
-  
FU-RF-60/16  
NEO, acier inoxydable mat

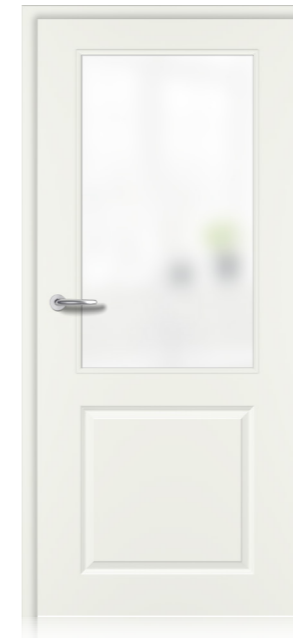

**5** CLASSIC CL2  
Weisslack Exklusiv 9010  
FLOAT SATINIERT, Ornamentglas  
FU-RF-60/16  
NEO, Edelstahl Matt  
CLASSIC CL2  
Blanc laqué exclusif 9010  
FLOAT SATINÉ, verre imprimé  
FU-RF-60/16  
NEO, acier inoxydable mat



**6** CLASSIC CL2+SP4  
Weisslack Exklusiv 9010  
FLOAT SATINIERT, Ornamentglas  
FU-RF-60/16  
NEO, Edelstahl Matt  
CLASSIC CL2+SP4  
Blanc laqué exclusif 9010  
FLOAT SATINÉ, verre imprimé  
FU-RF-60/16  
NEO, acier inoxydable mat





PROFILA  
Weisslack Exklusiv 9010

Die schönen Seiten des Lebens  
Les bons côtés de la vie

Neue und interessante Perspektiven der Raumgestaltung genießen.  
Apprécier de nouvelles perspectives intéressantes en matière  
d'aménagement intérieur.

QUERSCHNITT | COUPE TRANSVERSALE

RUNDKANTE | CHANT ARRONDI

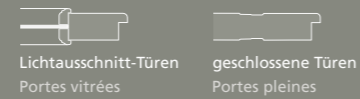

KARNIESKANTE

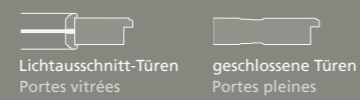

BESCHLAG  
NEO

GRAPHITSCHWARZ  
NOIR GRAPHITE



BB/RZ/WC



smart2lock

EDELSTAHL MATT  
ACIER INOXYDABLE MAT



BB/RZ/WC



smart2lock



**MODELL**  
**OBERFLÄCHE**  
**GLAS**  
**ZARGE**  
**BESCHLAG**  
**MODÈLE**  
**FINITION**  
**VERRE**  
**CHÂSSIS**  
**FERRURE**

**1** PROFILA PF4  
Weisslack Exklusiv 9010  
-  
FU-RF-60/16  
NEO, Graphitschwarz  
PROFILA PF4  
Blanc laqué exclusif 9010  
-  
FU-RF-60/16  
NEO, noir graphite

**2** PROFILA PFL4/2  
Weisslack Exklusiv 9010  
FLOAT SATINIERT, Ornamentglas  
FU-RF-60/16  
NEO, Graphitschwarz  
PROFILA PFL4/2  
Blanc laqué exclusif 9010  
FLOAT SATINÉ, verre imprimé  
FU-RF-60/16  
NEO, noir graphite

**3** PROFILA PF1  
Weisslack Exklusiv 9010  
-  
FU-RF-60/16  
NEO, Graphitschwarz  
PROFILA PF1  
Blanc laqué exclusif 9010  
-  
FU-RF-60/16  
NEO, noir graphite

**4** PROFILA PFL1  
Weisslack Exklusiv 9010  
FLOAT SATINIERT, Ornamentglas  
FU-RF-60/16  
NEO, Graphitschwarz  
PROFILA PFL1  
Blanc laqué exclusif 9010  
FLOAT SATINÉ, verre imprimé  
FU-RF-60/16  
NEO, noir graphite

**5** PROFILA PFL1+SP4  
Weisslack Exklusiv 9010  
FLOAT SATINIERT, Ornamentglas  
FU-RF-60/16  
NEO, Edelstahl Matt  
PROFILA PFL1+SP4  
Blanc laqué exclusif 9010  
FLOAT SATINÉ, verre imprimé  
FU-RF-60/16  
NEO, acier inoxydable mat

**6** PROFILA PF5  
Weisslack Exklusiv 9010  
-  
FU-RF-60/16  
NEO, Edelstahl Matt  
PROFILA PF5  
Blanc laqué exclusif 9010  
-  
FU-RF-60/16  
NEO, acier inoxydable mat

**7** PROFILA PFL5  
Weisslack Exklusiv 9010  
FLOAT SATINIERT, Ornamentglas  
FU-RF-60/16  
NEO, Edelstahl Matt  
PROFILA PFL5  
Blanc laqué exclusif 9010  
FLOAT SATINÉ, verre imprimé  
FU-RF-60/16  
NEO, acier inoxydable mat

**8** PROFILA PF3  
Weisslack Exklusiv 9010  
-  
FU-RF-60/16  
NEO, Edelstahl Matt  
PROFILA PF3  
Blanc laqué exclusif 9010  
-  
FU-RF-60/16  
NEO, acier inoxydable mat

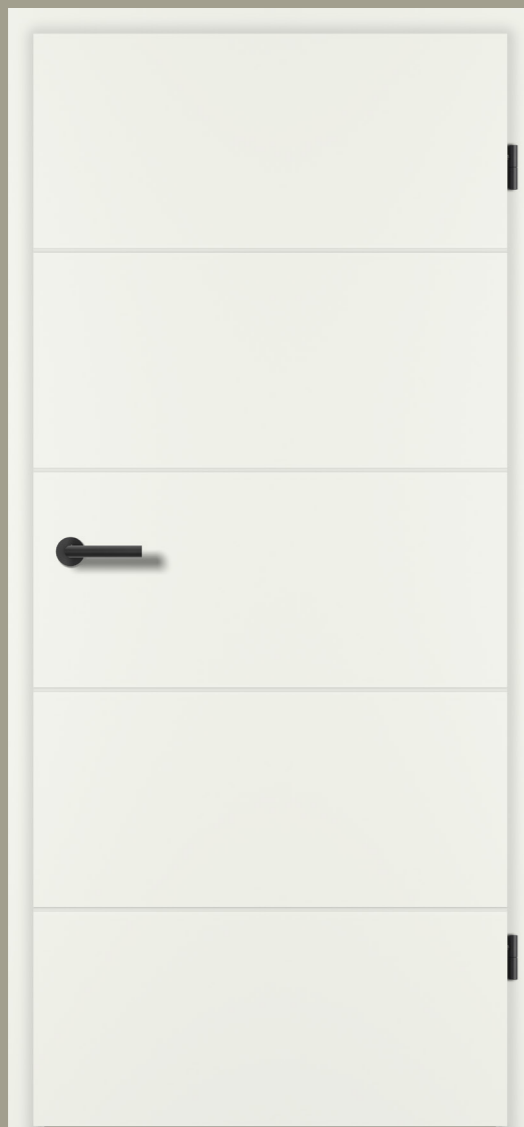

## ROYAL 200 Weisslack Exklusiv 9010

Für ein edles Ambiente  
Une ambiance noble

Die ROYAL-Weisslacktüren sind zentrale Elemente einer anspruchsvollen Raumgestaltung.  
Les portes blanc laqué ROYAL constituent les éléments clés d'un aménagement prestigieux.



Detail Linienfräsung  
Détail Rainure

### QUERSCHNITT | COUPE TRANSVERSALE

ECKIGE KANTE | CHANT DROIT

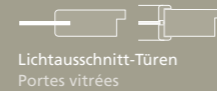

Lichtausschnitt-Türen  
Portes vitrées

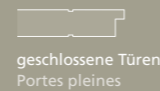

geschlossene Türen  
Portes pleines



### BESCHLAG MONO

GRAPHITSCHWARZ  
NOIR GRAPHITE



BB/RZ/WC



smart2lock

EDELSTAHL MATT  
ACIER INOXYDABLE MAT



BB/RZ/WC



smart2lock

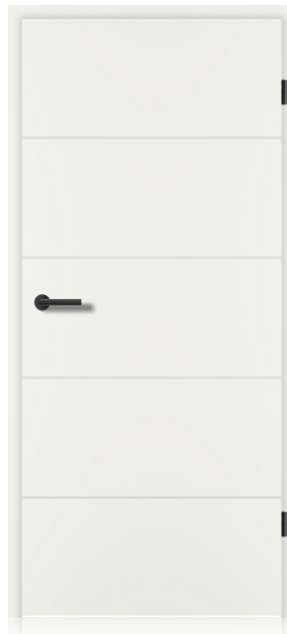

**1** ROYAL RY-251  
Weisslack Exklusiv 9010  
-  
FU-EC-55/16  
MONO, Graphitschwarz  
ROYAL RY-251  
Blanc laqué exclusif 9010  
-  
FU-EC-55/16  
MONO, noir graphite

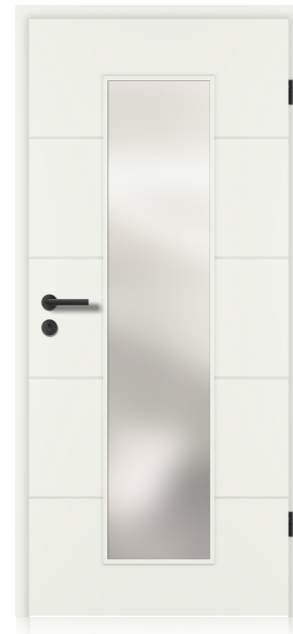

**2** ROYAL RY-251-LA3  
Weisslack Exklusiv 9010  
FLOAT SATINIERT, Ornamentglas  
FU-EC-55/16  
MONO, Graphitschwarz  
ROYAL RY-251-LA3  
Blanc laqué exclusif 9010  
FLOAT SATINÉ, verre imprimé  
FU-EC-55/16  
MONO, noir graphite

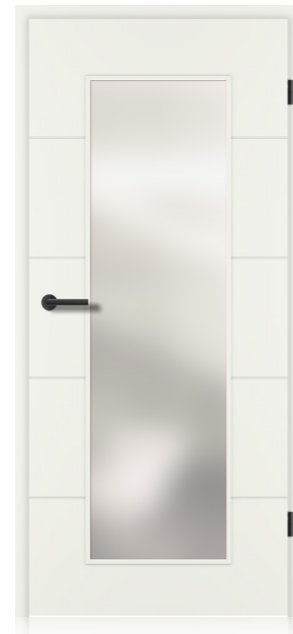

**3** ROYAL RY-251-LA1  
Weisslack Exklusiv 9010  
FLOAT SATINIERT, Ornamentglas  
FU-EC-55/16  
MONO, Graphitschwarz  
ROYAL RY-251-LA1  
Blanc laqué exclusif 9010  
FLOAT SATINÉ, verre imprimé  
FU-EC-55/16  
MONO, noir graphite

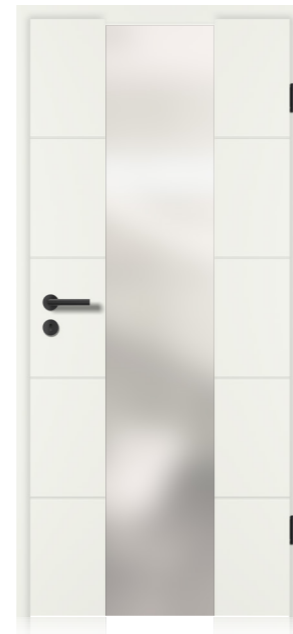

**4** ROYAL RY-251-LA5  
Weisslack Exklusiv 9010  
FLOAT SATINIERT, Ornamentglas  
FU-EC-55/16  
MONO, Graphitschwarz  
ROYAL RY-251-LA5  
Blanc laqué exclusif 9010  
FLOAT SATINÉ, verre imprimé  
FU-EC-55/16  
MONO, noir graphite



**5** ROYAL RY-251-LA2  
Weisslack Exklusiv 9010  
FLOAT SATINIERT, Ornamentglas  
FU-EC-55/16  
MONO, Edelhstahloptik Matt  
ROYAL RY-251-LA2  
Blanc laqué exclusif 9010  
FLOAT SATINÉ, verre imprimé  
FU-EC-55/16  
MONO, aspect inox mat



**6** ROYAL RY-254-LA25  
Weisslack Exklusiv 9010  
FLOAT SATINIERT, Ornamentglas  
FU-EC-55/16  
MONO, Edelhstahloptik Matt  
ROYAL RY-254-LA25  
Blanc laqué exclusif 9010  
FLOAT SATINÉ, verre imprimé  
FU-EC-55/16  
MONO, aspect inox mat

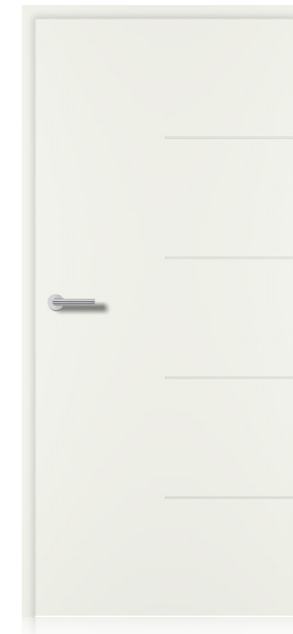

**7** ROYAL RY-254  
Weisslack Exklusiv 9010  
-  
FU-EC-55/16  
MONO, Edelhstahloptik Matt  
ROYAL RY-254  
Blanc laqué exclusif 9010  
-  
FU-EC-55/16  
MONO, aspect inox mat

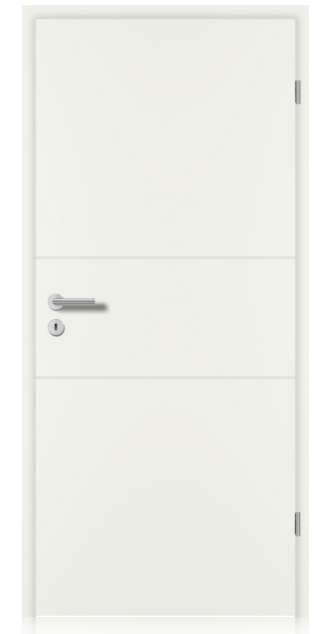

**8** ROYAL RY-233  
Weisslack Exklusiv 9010  
-  
FU-EC-55/16  
MONO, Edelhstahloptik Matt  
ROYAL RY-233  
Blanc laqué exclusif 9010  
-  
FU-EC-55/16  
MONO, aspect inox mat

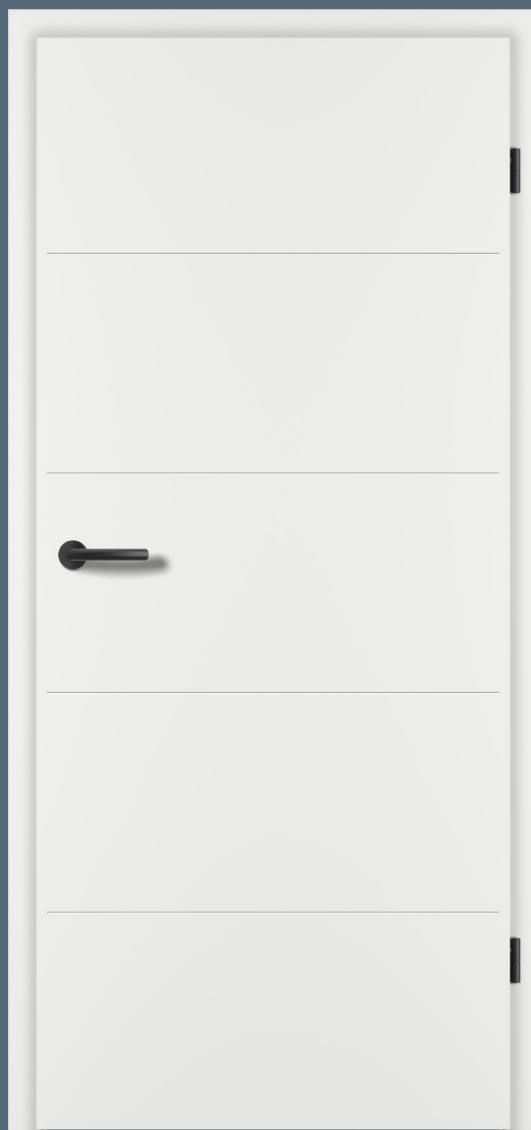

## ROYAL 400 Weisslack Exklusiv 9016

### Exklusive Visionen Des visions exclusives

Mit ROYAL-Weisslacktüren werden (T)räume Wirklichkeit.  
Avec les portes ROYAL blanc laqué, vos pièces de rêve deviennent réalité.



Detail V-Fuge  
Détail du chanfrein en V

#### QUERSCHNITT 9016 | COUPE TRANSVERSALE 9016

KLEINE RUNDKANTE | PETIT CHANT ARRONDI



Lichtausschnitt-Türen  
Portes vitrées



geschlossene Türen  
Portes pleines



## BESCHLAG NOVO

GRAPHITSCHWARZ  
NOIR GRAPHITE



BB/RZ/WC



smart2lock

EDELSTAHL MATT  
ACIER INOXYDABLE MAT



BB/RZ/WC



smart2lock

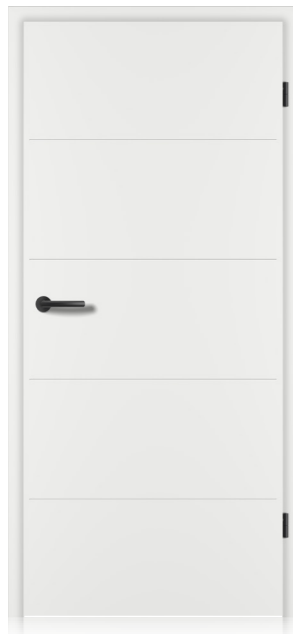

**1** ROYAL RY-451  
Weisslack Exklusiv 9016  
-  
FU-RFKR-60/16  
NOVO, Graphitschwarz  
MODÈLE  
ROYAL RY-451  
FINITION  
Blanc laqué exclusif 9016  
VERRE  
-  
CHÂSSIS  
FU-RFKR-60/16  
FERRURE  
NOVO, noir graphite

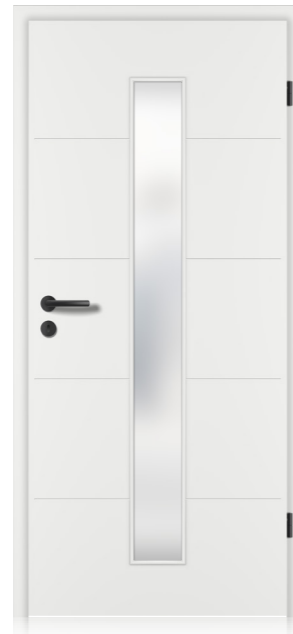

**2** ROYAL RY-451-LA2  
Weisslack Exklusiv 9016  
FLOAT SATINIERT, Ornamentglas  
FU-RFKR-60/16  
NOVO, Graphitschwarz  
MODÈLE  
ROYAL RY-451-LA2  
FINITION  
Blanc laqué exclusif 9016  
FLOAT SATINÉ, verre imprimé  
FU-RFKR-60/16  
NOVO, noir graphite

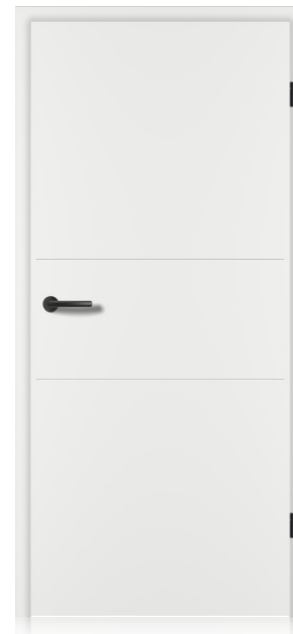

**3** ROYAL RY-433  
Weisslack Exklusiv 9016  
-  
FU-RFKR-60/16  
NOVO, Graphitschwarz  
MODÈLE  
ROYAL RY-433  
FINITION  
Blanc laqué exclusif 9016  
-  
FU-RFKR-60/16  
NOVO, noir graphite



**4** ROYAL RY-433-LA1  
Weisslack Exklusiv 9016  
FLOAT SATINIERT, Ornamentglas  
FU-RFKR-60/16  
NOVO, Graphitschwarz  
MODÈLE  
ROYAL RY-433-LA1  
FINITION  
Blanc laqué exclusif 9016  
FLOAT SATINÉ, verre imprimé  
FU-RFKR-60/16  
NOVO, noir graphite



**5** ROYAL RY-433-LA3  
Weisslack Exklusiv 9016  
FLOAT SATINIERT, Ornamentglas  
FU-RFKR-60/16  
NOVO, Edelstahloptik Matt  
MODÈLE  
ROYAL RY-433-LA3  
FINITION  
Blanc laqué exclusif 9016  
FLOAT SATINÉ, verre imprimé  
FU-RFKR-60/16  
NOVO, aspect inox mat



**6** ROYAL RY-433-S  
Weisslack Exklusiv 9016  
-  
FU-RFKR-60/16  
NOVO, Edelstahloptik Matt  
MODÈLE  
ROYAL RY-433-S  
FINITION  
Blanc laqué exclusif 9016  
-  
FU-RFKR-60/16  
NOVO, aspect inox mat



**7** ROYAL RY-433-S-LA2B  
Weisslack Exklusiv 9016  
FLOAT SATINIERT, Ornamentglas  
FU-RFKR-60/16  
NOVO, Edelstahloptik Matt  
MODÈLE  
ROYAL RY-433-S-LA2B  
FINITION  
Blanc laqué exclusif 9016  
FLOAT SATINÉ, verre imprimé  
FU-RFKR-60/16  
NOVO, aspect inox mat

# Türkanten und Zargenausführungen

## Chants de porte et modèles de châssis



**TÜRBLATT TB-EC**  
Eckige Kante

**ZARGE FU-EC 55/16 MM**  
Bekleidung eckig  
(55 mm und 80/22 mm)  
Futterplatte eckig

**PANNEAU DE PORTE TB-EC**  
Chant droit

**CHÂSSIS FU-EC 55/16 MM**  
Cadre, faux cadre droit  
(55 mm et 80/22 mm)  
Embrasure droite

**TÜRBLATT TB-RPKR**  
Kleine Rundkante

**ZARGE FU-RFKR 60/16 MM**  
Bekleidung rund  
(60 mm und 80/22 mm)  
Futterplatte rund

**PANNEAU DE PORTE TB-RPKR**  
Petit chant arrondi

**CHÂSSIS FU-RFKR 60/16 MM**  
Cadre, faux cadre arrondi  
(60 mm et 80/22 mm)  
Embrasure arrondie



**WEISSLACK 9016**  
BLANC LAQUÉ 9016

**TÜRBLATT TB-RU/RP**  
Rundkante

**ZARGE FU-RF 60/16 MM**  
Bekleidung rund (60 mm)  
Futterplatte rund

**PANNEAU DE PORTE TB-RU/RP**  
Chants arrondi

**CHÂSSIS FU-RF 60/16 MM**  
Cadre, faux cadre arrondi (60 mm)  
Embrasure arrondie



**WEISSLACK 9010**  
BLANC LAQUÉ 9010

**TÜRBLATT TB-RU/RP**  
Rundkante

**ZARGE FU-RF 80/22 MM**  
Bekleidung rund (80/22 mm)  
Futterplatte rund

**PANNEAU DE PORTE TB-RU/RP**  
Chant arrondi

**CHÂSSIS FU-RF 80/22 MM**  
Cadre, faux cadre arrondi (60 mm)  
Embrasure arrondie



**WEISSLACK 9010**  
BLANC LAQUÉ 9010

**TÜRBLATT TB-KA**  
Karnieskante

**ZARGE FU-PR 65/19 MM**  
Bekleidung profiliert (65 mm)  
Futterplatte rund

**PANNEAU DE PORTE TB-KA**  
Chant mouluré

**CHÂSSIS FU-PR 65/19 MM**  
Cadre, faux cadre mouluré (65 mm)  
Embrasure arrondie



**WEISSLACK 9010**  
BLANC LAQUÉ 9010

**TÜRBLATT TB-RU/RP**  
Rundkante

**ZARGE FU-SLF 70/22,7**  
Bekleidung softline (70/22,7 mm)  
Futterplatte rund

**PANNEAU DE PORTE RU/RP**  
Chant arrondi

**CHÂSSIS FU-SLF 70/22,7 MM**  
Cadre, faux cadre softline (70/22,7 mm)  
Embrasure arrondie



**WEISSLACK 9010**  
BLANC LAQUÉ 9010

**TÜRBLATT TB-RPKR**  
Rundkante

**ZARGE FU-PRIMO-100/25**  
Bekleidung rund (100 mm)  
Futterplatte rund

**PANNEAU DE PORTE RPKR**  
Chant arrondi

**CHÂSSIS FU-PRIMO 100/25 MM**  
Cadre, faux cadre arrondi (100 mm)  
Embrasure arrondie



**WEISSLACK 9016**  
BLANC LAQUÉ 9016



**WEISSLACK 9010**  
BLANC LAQUÉ 9010

### LACK

Makellose Lackierungen sind einfach faszinierend. Mit hochwertigen, umweltschonenden UV-härtenden Acryllacken, modernen Walz- und Spritzverfahren und permanenter Qualitätskontrolle sorgen wir dafür, dass Arbonia-Türen auch auf Jahre hinaus nichts von dieser Faszination verlieren. So sind unsere seidenmatten Weisslacktüren überall dort zu Hause, wo klassisches Türdesign und zeitgemässer Pflegekomfort gefragt sind.

### LAQUAGE

Des laquages impeccables et fascinants. Nos laquages acryliques de haute qualité respectent l'environnement, sont imperméables aux UV et sont soumis, en permanence, à des contrôles de qualité. Ils sont appliqués avec des méthodes modernes et tout est mis en oeuvre pour que les portes Arbonia vous donnent entière satisfaction durant de longues années. Nos portes blanches satinées sont synonymes de design classique et de facilité d'entretien.

# Gesamtübersicht WEISSLACK-Programm

## Vue d'ensemble Programme BLANC LAQUÉ

STANDARD | STANDARD

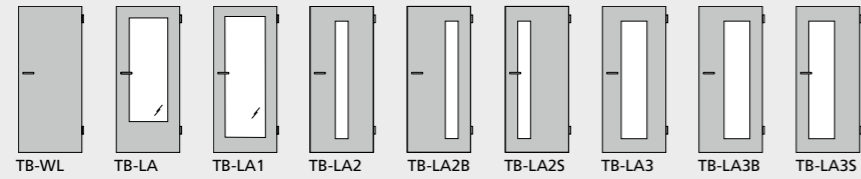

**OBERFLÄCHEN**  
FINITIONS

- WEISSLACK 9010  
BLANC LAQUÉ 9010
- WEISSLACK 9016  
BLANC LAQUÉ 9016
- WEISSLACK EXKLUSIV 9010  
BLANC LAQUÉ EXCLUSIF 9010
- WEISSLACK EXKLUSIV 9016  
BLANC LAQUÉ EXCLUSIF 9016

**LACKIERUNG**  
LAQUAGE

- 9010
- 9016
- 9010
- 9016

**TÜRKANTEN**  
CHANTS

- RP EC 9010
- RPKR 9016
- RP EC 9010
- RPKR 9016

ELEGANCE-PROGRAMM | GAMME ELEGANCE

**PRIMO**

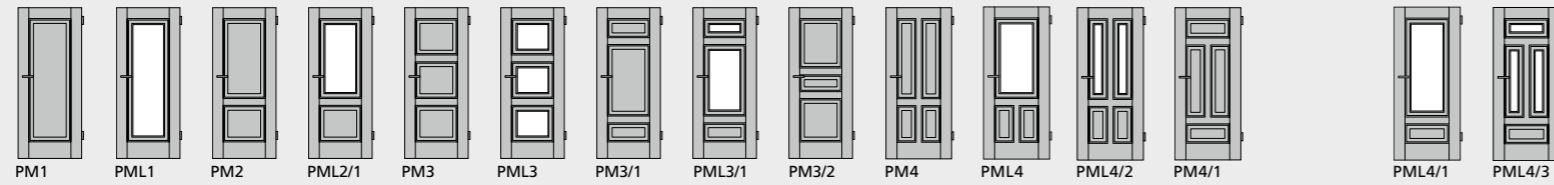

**OBERFLÄCHEN**  
FINITIONS

- WEISSLACK EXKLUSIV 9010  
BLANC LAQUÉ EXCLUSIF 9010
- WEISSLACK EXKLUSIV 9016  
BLANC LAQUÉ EXCLUSIF 9016

**LACKIERUNG**  
LAQUAGE

- 9010
- 9016

**TÜRKANTEN**  
CHANTS

- EC 9010
- RPKR 9016

**MODENA**

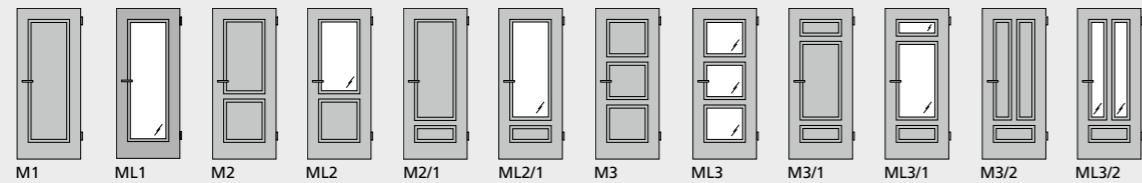

**OBERFLÄCHEN**  
FINITIONS

- WEISSLACK EXKLUSIV 9010  
BLANC LAQUÉ EXCLUSIF 9010
- WEISSLACK EXKLUSIV 9016  
BLANC LAQUÉ EXCLUSIF 9016

**LACKIERUNG**  
LAQUAGE

- 9010
- 9016

**TÜRKANTEN**  
CHANTS

- EC 9010
- RPKR 9016

**CLASSIC**

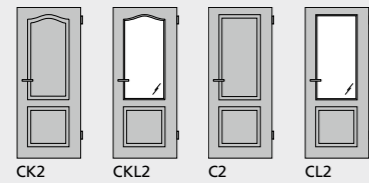

**OBERFLÄCHEN**  
FINITIONS

- WEISSLACK EXKLUSIV 9010  
BLANC LAQUÉ EXCLUSIF 9010
- WEISSLACK EXKLUSIV 9016  
BLANC LAQUÉ EXCLUSIF 9016

**LACKIERUNG**  
LAQUAGE

- 9010
- 9016

**TÜRKANTEN**  
CHANTS

- RU KA 9010
- RUKR 9016

**PROFILA**

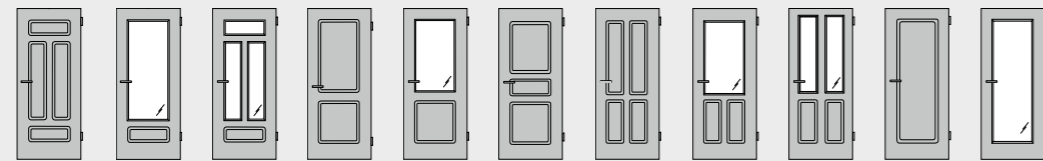

**OBERFLÄCHEN**  
FINITIONS

- WEISSLACK EXKLUSIV 9010  
BLANC LAQUÉ EXCLUSIF 9010

**LACKIERUNG**  
LAQUAGE

- 9010

**TÜRKANTEN**  
CHANTS

- RP KA 9010

# Gesamtübersicht WESSLACK-Programm

## Vue d'ensemble Programme BLANC LAQUÉ

ROYAL-PROGRAMM | GAMME ROYAL

**ROYAL 200**

RY-210 RY-210-LA1 RY-210-LA2 RY-210-LA3 RY-210-LA4 RY-210-LA5 RY-231 RY-231-LA1 RY-231-LA2 RY-231-LA3 RY-231-LA4 RY-231-LA5 RY-233

RY-251-LA4 RY-251-LA5 RY-252 RY-252-LA1 RY-252-LA2 RY-252-LA3 RY-252-LA4 RY-252-LA5 RY-253 RY-253-LA1 RY-253-LA2 RY-253-LA3 RY-253-LA4

RY-233-LA1 RY-233-LA2 RY-233-LA3 RY-233-LA4 RY-233-LA5 RY-251 RY-251-LA1 RY-251-LA2 RY-251-LA3

RY-253-LA5 RY-221 RY-222 RY-232 RY-234 RY-235 RY-254 RY-254-LA2S

**ROYAL 400**

RY-433 RY-433-LA1 RY-433-LA2 RY-433-LA3 RY-443-S RY-443-S-LA2B RY-451 RY-451-LA1 RY-451-LA2 RY-451-LA3

**OBERFLÄCHEN FINITIONS**

WESSLACK EXKLUSIV 9010  
BLANC LAQUÉ EXCLUSIF 9010

**LACKIERUNG LAQUAGE**

**TÜRKANTEN CHANTS**

**LACKIERUNG LAQUAGE**

**TÜRKANTEN CHANTS**

9016

GLÄSER | VERRES

### MODERNE ORNAMENTGLÄSER | VERRES IMPRIMÉS MODERNES

LIGNO PETALI PANNO

WOOD1-DA WOOD1-DQ WOOD2-DA WOOD2-DQ

### KLASSISCHE ORNAMENTGLÄSER | VERRES IMPRIMÉS CLASSIQUES

CHINCHILLA WEISS CHINCHILLA BLANC

FLOAT KLAR FLOAT CLAIR

FLOAT SATINIERT FLOAT SATINÉ

GOTHIK WEISS\* GOTHIK BLANC\*

KATHEDRAL WEISS\* KATHEDRAL BLANC\*

MASTERCARRÉ WEISS MASTERCARRÉ BLANC

SILVIT 178 WEISS SILVIT 178 BLANC

UADI WEISS UADI BLANC

\*Nicht als Ganzgläser oder LA4, LA5 erhältlich  
\*Non disponibles pour les portes tout-verre ou LA4, LA5

TOP-BESCHLÄGE | FERRURES TOP

**MONO**

WÄHLBAR IN EDELSTAHL MATT ODER GRAPHITSCHWARZ  
DISPONIBLE EN ACIER INOXYDABLE MAT OU NOIR GRAPHITE

**NOVO**

WÄHLBAR IN EDELSTAHL MATT ODER GRAPHITSCHWARZ  
DISPONIBLE EN ACIER INOXYDABLE MAT OU NOIR GRAPHITE

**NEO**

WÄHLBAR IN EDELSTAHL MATT ODER GRAPHITSCHWARZ  
DISPONIBLE EN ACIER INOXYDABLE MAT OU NOIR GRAPHITE



## Schichtstoff-Programm | Gamme Stratifié



Schichtstoff-Türen (HPL) sind selbst härtesten Anforderungen gewachsen und werden weitestgehend in Gebäuden eingesetzt, in denen Türen einer intensiven Nutzung unterliegen

Les portes en stratifié (HPL) répondent aux exigences les plus strictes et conviennent aux bâtiments dans lesquels les portes sont soumises à un usage intensif.



STANDARD  
0160-60 Silver Grey & 0901-60 Black

Oberflächen für eine intensive Nutzung

Des finitions adaptées à un usage intensif

Den härtesten Anforderungen gewachsen.  
À la hauteur des exigences les plus sévères.

QUERSCHNITT | COUPE TRANSVERSALE

ECKIGE KANTE | CHANT DROIT

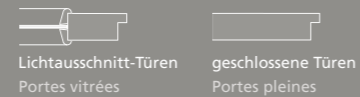

PREMIUMKANTE | CHANT PREMIUM

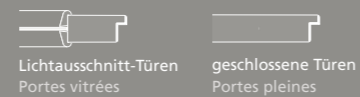

BESCHLAG  
MONO

GRAPHITSCHWARZ  
NOIR GRAPHITE



BB/RZ/WC



smart2lock

EDELSTAHL MATT  
ACIER INOXYDABLE MAT



BB/RZ/WC



smart2lock



1 STANDARD TB-DA  
0160-60 Silver Grey



2 STANDARD TB-LA-DA  
0160-60 Silver Grey  
FLOAT SATINIERT, Ornamentglas  
FU-EC 55/20  
MONO, Graphitschwarz



3 STANDARD TB-LA3-DA  
0160-60 Silver Grey  
FLOAT SATINIERT, Ornamentglas  
FU-EC 55/20  
MONO, Graphitschwarz



4 STANDARD TB-LA2-DA  
0160-60 Silver Grey  
FLOAT SATINIERT, Ornamentglas  
FU-EC 55/20  
MONO, Graphitschwarz

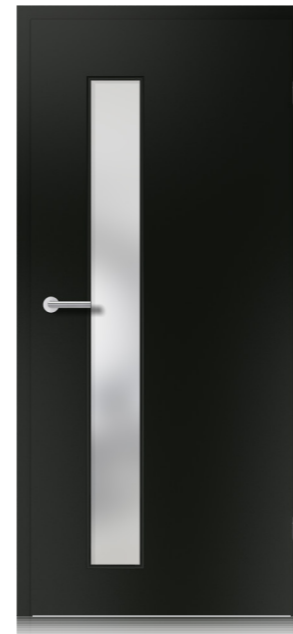

5 STANDARD TB-LA2S-DA  
0901-60 Black  
FLOAT SATINIERT, Ornamentglas  
FU-EC 55/20  
MONO, Edeldahl matt



6 STANDARD TB-LA-DA  
0901-60 Black  
FLOAT SATINIERT, Ornamentglas  
FU-EC 55/20  
MONO, Edeldahl matt

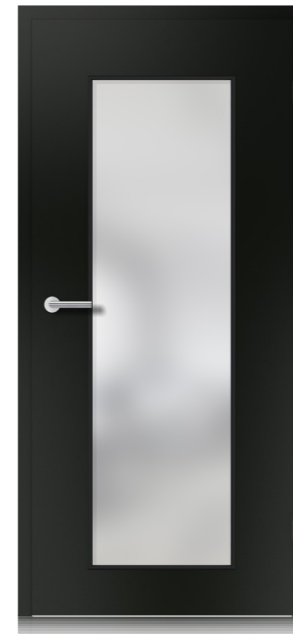

7 STANDARD TB-LA1-DA  
0901-60 Black  
FLOAT SATINIERT, Ornamentglas  
FU-EC 55/20  
MONO, Edeldahl matt



8 STANDARD TB-DA  
0901-60 Black  
FU-EC 55/20  
MONO, Edeldahl matt

MODELL  
OBERFLÄCHE  
GLAS  
ZARGE  
BESCHLAG  
MODÈLE  
FINITION  
VERRE  
CHÂSSIS  
FERRURE

PORTES STANDARD TB-DA  
0160-60 Silver Grey  
-  
FU-EC 55/20  
MONO, noir graphite

PORTES STANDARD TB-LA-DA  
0160-60 Silver Grey  
FLOAT SATINÉ, VERRE IMPRIMÉ  
FU-EC 55/20  
MONO, noir graphite

PORTES STANDARD TB-LA3-DA  
0160-60 Silver Grey  
FLOAT SATINÉ, verre imprimé  
FU-EC 55/20  
MONO, noir graphite

PORTES STANDARD TB-LA2-DA  
0160-60 Silver Grey  
FLOAT SATINÉ, verre imprimé  
FU-EC 55/20  
MONO, noir graphite

PORTES STANDARD TB-LA2S-DA  
0901-60 Black  
FLOAT SATINÉ, verre imprimé  
FU-EC 55/20  
MONO, acier inoxydable mat

PORTES STANDARD TB-LA-DA  
0901-60 Black  
FLOAT SATINÉ, verre imprimé  
FU-EC 55/20  
MONO, acier inoxydable mat

PORTES STANDARD TB-LA1-DA  
0901-60 Black  
FLOAT SATINÉ, verre imprimé  
FU-EC 55/20  
MONO, acier inoxydable mat

PORTES STANDARD TB-DA  
0901-60 Black  
FU-EC 55/20  
MONO, Acier inoxydable mat



# Schichtstoff DESIGN-Programm

## Gamme stratifié DESIGN

# Schichtstoff EXPRESS-Programm

## Gamme stratifié EXPRESS



Alle Arbonia Schichtstoffdekore 0,8 mm alternativ auch in CPL erhältlich  
Tous les films stratifiés Arbonia 0,8 mm sont également disponibles en CPL

KARO WHITE PK2 KARO WHITE KARO WHITE PK2 KARO WHITE	KARO BEIGE PK2 KARO BEIGE KARO BEIGE PK2 KARO BEIGE	KARO GREY PK2 KARO GREY KARO GREY PK2 KARO GREY	KARO DARK PK2 KARO DARK KARO DARK PK2 KARO DARK	AHORN PUR PK2 MITTELBRAUN ÉRABLE PUR PK2 BRUN MOYEN	BUCHE PUR PK2 MITTELBRAUN HÊTRE PUR PK2 BRUN MOYEN
TOUCH EICHE DA PK2 EICHEBRAUN TOUCH CHÊNE DA PK2 BRUN CHÊNE	TOUCH EICHE DQ PK2 EICHEBRAUN TOUCH CHÊNE DQ PK2 BRUN CHÊNE	TOUCH EICHE ASTIG DA PK2 EICHEBRAUN TOUCH CHÊNE NOUEUX DA PK2 BRUN CHÊNE	TOUCH EICHE ASTIG DQ PK2 EICHEBRAUN TOUCH CHÊNE NOUEUX DQ PK2 BRUN CHÊNE	TOUCH OAK NATURE DA PK2 MITTELBRAUN TOUCH OAK NATURE DA PK2 BRUN MOYEN	TOUCH OAK NATURE DQ PK2 MITTELBRAUN TOUCH OAK NATURE DQ PK2 BRUN MOYEN
TOUCH OAK WHITE DA PK2 SILBERGRAU TOUCH OAK WHITE DA PK2 GRIS ARGENTÉ	TOUCH OAK WHITE DQ PK2 SILBERGRAU TOUCH OAK WHITE DQ PK2 GRIS ARGENTÉ	TOUCH OAK CREME DA PK2 HELLBRAUN TOUCH OAK CREME DA PK2 BRUN CLAIR	TOUCH OAK CREME DQ PK2 HELLBRAUN TOUCH OAK CREME DQ PK2 BRUN CLAIR	TOUCH PINIE DA PK2 SEIDENGRAU TOUCH PIN DA PK2 GRIS SOIE	TOUCH PINIE DQ PK2 SEIDENGRAU TOUCH PIN DQ PK2 GRIS SOIE
EICHE PK2 MITTELBRAUN CHÊNE PK2 BRUN MOYEN	ESCHE WEISS PK2 WEISS 9010 FRÊNE BLANC PK2 BLANC 9010	TOUCH WHITELINE DA PK2 WEISS 9010 TOUCH WHITELINE DA PK2 BLANC 9010	TOUCH WHITELINE DQ PK2 WEISS 9010 TOUCH WHITELINE DQ PK2 BLANC 9010	TOUCH GREYLINE DA PK2 SEIDENGRAU TOUCH GREYLINE DA PK2 GRIS SOIE	TOUCH GREYLINE DQ PK2 SEIDENGRAU TOUCH GREYLINE DQ PK2 GRIS SOIE

23 der gängigsten Schichtstoffoberflächen mit kurzer Lieferzeit  
23 des finitions stratifiées les plus courantes, livraison rapide

WEISSLACK 9016* PK2 WEISS 9016 BLANC LAQUÉ 9016* PK2 BLANC 9016	WEISSLACK 9010* PK2 WEISS 9010 BLANC LAQUÉ 9010* PK2 BLANC 9010	SILBERGRAU* PK2 SILBERGRAU SILBERGRAU* PK2 GRIS ARGENTÉ	SEIDENGRAU* PK2 SEIDENGRAU GRIS SOIE* PK2 GRIS SOIE	STAUBGRAU* PK2 STAUBGRAU GRIS POUSSIÈRE* PK2 GRIS POUSSIÈRE	GRAPHITGRAU* PK2 GRAPHITGRAU GRIS GRAPHITE* PK2 GRIS GRAPHITE
EICHE ALTHOLZ DA* PK2 EICHEBRAUN VIEUX BOIS DE CHÊNE DA* PK2 BRUN CHÊNE	EICHE ALTHOLZ DQ* PK2 EICHEBRAUN VIEUX BOIS DE CHÊNE DQ* PK2 BRUN CHÊNE	RESOPAL 9417/60 PK2 WEISS 9016 RESOPAL 9417/60 PK2 BLANC 9016	RESOPAL 0105/60 PK2 WEISSLACK 9010 RESOPAL 0105/60 PK2 BLANC 9010	RESOPAL 0140/60 PK2 SILBERGRAU RESOPAL 0140/60 PK2 GRIS ARGENTÉ	RESOPAL 0160/60 PK2 SILBERGRAU RESOPAL 0160/60 PK2 GRIS ARGENTÉ
RESOPAL 010622/60 PK2 GRAPHITGRAU RESOPAL 010622/60 PK2 GRIS GRAPHITE	EGGER H1180ST22 PK2 MITTELBRAUN EGGER H1180ST22 PK2 BRUN MOYEN	EGGER H180 ST86 PK2 MITTELBRAUN EGGER H180 ST86 PK2 BRUN MOYEN	EGGER W980 ST15 PK2 WEISS 9016 EGGER W980 ST15 PK2 BLANC 9016	EGGER W1000SM PK2 WEISS 9016 EGGER W1000SM PK2 BLANC 9016	PFLEIDERER U11026 SD PK2 WEISS 9010 PFLEIDERER U11026 SD PK2 BLANC 9010
PFLEIDERER U11209 SD PK2 WEISS 9016 PFLEIDERER U11209 SD PK2 BLANC 9016	PFLEIDERER U11077SM PK2 WEISS 9010 PFLEIDERER U11077SM PK2 BLANC 9010	PFLEIDERER U12188 SD PK2 SILBERGRAU PFLEIDERER U12188 SD PK2 GRIS ARGENTÉ	PFLEIDERER U12115 SD PK2 STAUBGRAU PFLEIDERER U12115 SD PK2 GRIS POUSSIÈRE	PFLEIDERER U12000 SD PK2 GRAPHITGRAU PFLEIDERER U12000 SD PK2 GRIS GRAPHITE	

\*Oberflächen auch im Designprogramm erhältlich  
\*Finitions également disponibles dans la gamme Design



Premiumkanten in Kombination mit Schichtstoff | Chant premium assorti au stratifié

KANTENFARBE TEINTE DU CHANT	PK2 WEISS 9016 PK2 BLANC 9016	PK2 WEISS 9010 PK2 BLANC 9010	PK2 KARO WHITE PK2 KARO WHITE	PK2 KARO BEIGE PK2 KARO BEIGE	PK2 KARO GREY PK2 KARO GREY	PK2 KARO DARK PK2 KARO DARK	PK2 GRAPHITGRAU PK2 GRIS GRAPHITE

PK2 STAUBGRAU PK2 GRIS POUSSIÈRE	PK2 SEIDENGRAU PK2 GRIS SOIE	PK2 SILBERGRAU PK2 GRIS ARGENTÉ	PK2 HELLBRAUN PK2 BRUN CLAIR	PK2 EICHEBRAUN PK2 BRUN CHÊNE	PK2 MITTELBRAUN PK2 BRUN MOYEN	PK2 DUNKELBRAUN PK2 BRUN FONCÉ	PK2 SCHWARZ PK2 BRUN NOIR

# Schichtstoff INDUSTRIE-Programm

## Gamme stratifié INDUSTRIE

**Gesamte Türenkollektion der vier Industriepartner, ca. 400 Varianten**  
**Collection complète de portes des quatre partenaires industriels, environ 400 variantes**



FUNDERMAX ist Inspirationsquelle und Ermöglicher für atemberaubendes Innendesign.  
 FUNDERMAX est une source d'inspiration et permet un design d'intérieur fascinant.



Das PFLEIDERER Türenprogramm: verarbeitungsoptimierte Werkstoffe, dekorgleich umsetzbar, in kompromisslos guter Qualität.  
 La gamme de portes PFLEIDERER : des matériaux optimisés pour la transformation, réalisables dans le même film, d'une qualité sans compromis.



RESOPAL: Perfekt für die anspruchsvolle Raumgestaltung.  
 RESOPAL: Parfait pour un aménagement intérieur de qualité.

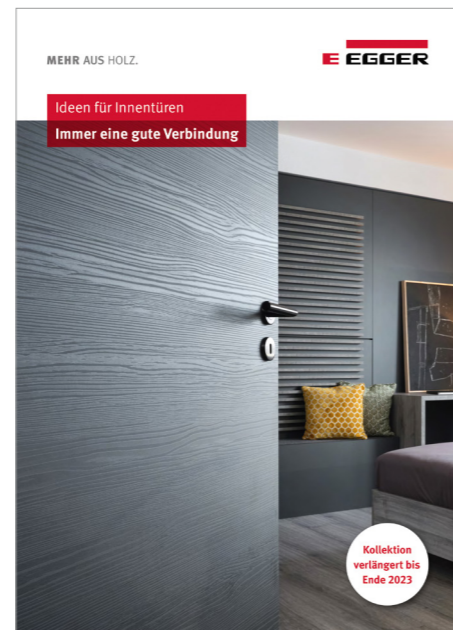

Lassen Sie sich von EGGER Produkten für Innentüren, den attraktiven Dekoren und deren Kombinationsmöglichkeiten inspirieren.  
 Laissez-vous inspirer par les produits EGGER pour portes intérieures, les décors attractifs et leurs combinaisons possibles.



# Allgemeine Informationen

## Informations générales

### VORTEILE SCHICHTSTOFF

- Schichtstoff wird durch das Hochdruck-Verpressen mehrerer Lagen Papier mit härtendem Kunstharz hergestellt.
- Der hohe Pressdruck lässt eine geschlossenen porenfreie Oberfläche entstehen.
- Schichtstoff-Oberflächen sind sehr strapazierfähig, kratz- und stossfest, schmutzunempfindlich, lichtecht und gegen haushaltsübliche Chemikalien resistent, siedendes Wasser, feuchte oder trockene Hitze hinterlassen keine Spuren.
- Schichtstoff-Türen sind robust und eignen sich bei Räumen wo Türen einer hohen Beanspruchung ausgesetzt sind. Besonders geeignet für Kindergärten, Schulen, Krankenhäuser, Hotels, Büros, Praxen, etc.
- Extrem pflegeleicht und leicht zu reinigen.
- Schichtstoff-Oberflächen bieten grosse Gestaltungsmöglichkeiten, viele Dekore und Oberflächen verfügbar.

### AVANTAGES DU STRATIFIÉ

- Le stratifié est fabriqué en comprimant à haute pression plusieurs couches de papier avec de la résine synthétique durcissante.
- La haute pression permet d'obtenir une finition fermée sans pores.
- Les finitions stratifiées sont très résistantes à l'usure, aux rayures et aux chocs, aux salissures, à la lumière et aux produits chimiques courants. L'eau bouillante, la chaleur humide ou sèche ne laissent aucune trace.
- Les portes en stratifié sont robustes et conviennent aux pièces où les portes sont soumises à de fortes contraintes. Particulièrement adaptées aux jardins d'enfants, écoles, hôpitaux, hôtels, bureaux, cabinets médicaux, etc.
- Extrêmement faciles à entretenir et à nettoyer.
- Les finitions stratifiées offrent de grandes possibilités d'aménagement, de nombreux films et finitions.

### KANTENAUSFÜHRUNGEN

Alle Kanten auch als Doppelfalz und gefälzt-flächenbündig möglich

### MODÈLES DE CHANTS

Tous les chants sont également disponibles en double feuillure et en feuillure à fleur de la surface.

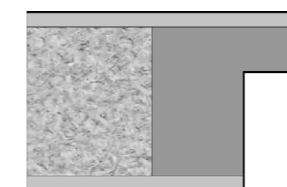

ECKIGE KANTE  
CHANT DROIT

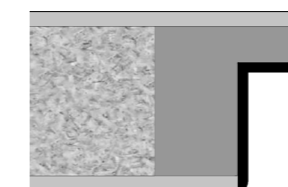

PREMIUMKANTE  
CHANT PREMIUM

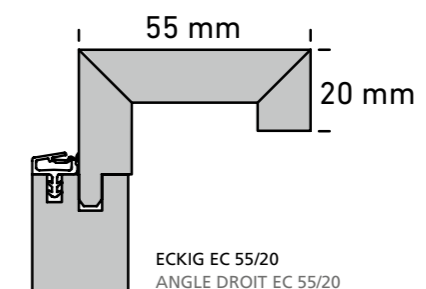

ECKIG EC 55/20  
ANGLE DROIT EC 55/20

# Gesamtübersicht SCHICHTSTOFF-Programm

## Vue d'ensemble de la gamme STRATIFIÉ (HPL)

STANDARD | STANDARD

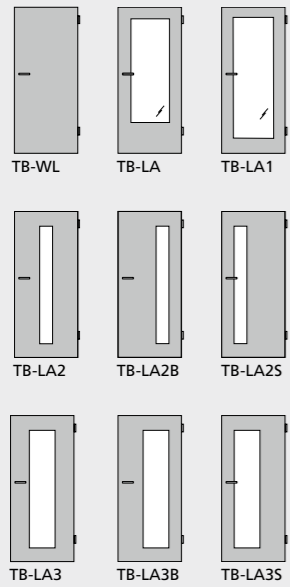

OBERFLÄCHEN | FINITIONS

### Schichtstoff DESIGN-Programm Gamme stratifié DESIGN



KARO WHITE, KARO BEIGE, KARO GREY, KARO DARK, AHORN PUR, BUCHE PUR  
KARO WHITE, KARO BEIGE, KARO GREY, KARO DARK, ÉRABLE PUR, CPL HÊTRE PUR



TOUCH EICHE DA/DQ, TOUCH EICHE ASTIG DA/DQ, TOUCH OAK NATURE DA/DQ  
TOUCH CHÊNE DA/DQ, TOUCH CHÊNE NOUEUX DA/DQ, TOUCH OAK NATURE DA/DQ



TOUCH OAK WHITE DA/DQ, TOUCH OAK CREME DA/DQ, TOUCH PINIE DA/DQ  
TOUCH OAK WHITE DA/DQ, TOUCH OAK CREME DA/DQ, TOUCH PIN DA/DQ



EICHE, ESCHWEISS, TOUCH WHITELINE DA/DQ, TOUCH GREYLINE DA/DQ  
CHÊNE, FRÊNE BLANC, TOUCH WHITELINE DA/DQ, TOUCH GREYLINE DA/DQ

### Schichtstoff EXPRESS-Programm Gamme stratifié EXPRESS



WEISSLACK 9016, WEISSLACK 9010, SEIDENGRAU, STAUBGRAU, GRAPHITGRAU  
BLANC LAQUÉ 9016, BLANC LAQUÉ 9010, GRIS SOIE, GRIS POUSSIÈRE, GRIS GRAPHITE



EICHE ALTHOLZ DA/DQ, RESOPAL 9417/60, RESOPAL 0105/60, RESOPAL 0140/60, RESOPAL 0160/60  
VIEUX BOIS DE CHÊNE DA/DQ, RESOPAL 9417/60, RESOPAL 0105/60, RESOPAL 0140/60, RESOPAL 0160/60



RESOPAL 010622/60, EGGER H1180ST22, EGGER H180 ST86, EGGER W980 ST15, EGGER W1000SM, PFLEIDERER U11026 SD



PFLEIDERER U11209 SD, PFLEIDERER U11077SM, PFLEIDERER U12188 SD, PFLEIDERER U12115 SD, PFLEIDERER U12000 SD

TÜR KANTEN  
CHANTS



### PREMIUMKANTEN-FARBEN | TEINTES DU CHANT PREMIUM



PK2 GRAPHITGRAU, PK2 STAUBGRAU, PK2 SEIDENGRAU, PK2 SILBERGRAU  
PK2 GRIS GRAPHITE, PK2 GRIS POUSSIÈRE, PK2 GRIS SOIE, PK2 GRIS ARGENTÉ



PK2 KARO WHITE, PK2 KARO BEIGE, PK2 KARO GREY, PK2 KARO DARK  
PK2 KARO WHITE, PK2 KARO BEIGE, PK2 KARO GREY, PK2 KARO DARK



PK2 HELLBRAUN, PK2 EICHEBRAUN, PK2 MITTELBRAUN, PK2 DUNKELBRAUN  
PK2 BRUN CLAIR, PK2 CHÊNE BRUN, PK2 BRUN MOYEN, PK2 BRUN FONCÉ



PK2 SCHWARZ, PK2 WEISS 9016, PK2 WEISS 9010  
PK2 NOIR, PK2 BLANC 9016, PK2 BLANC 9010

GLÄSER | VERRES

### MODERNE ORNAMENTGLÄSER | VERRES IMPRIMÉS MODERNES

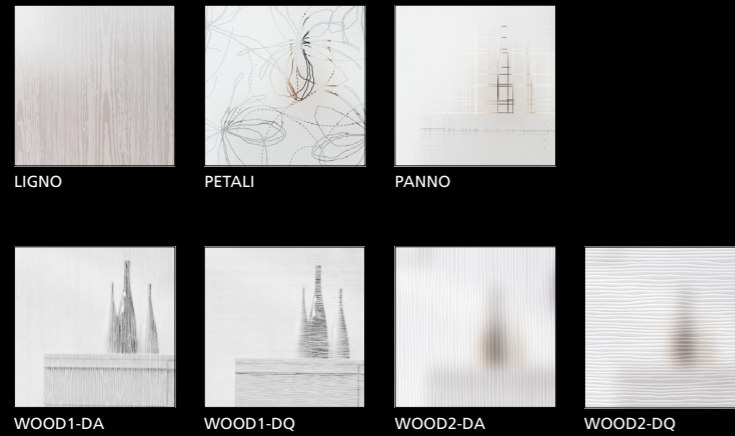

### KLASSISCHE ORNAMENTGLÄSER | VERRES IMPRIMÉS CLASSIQUES



TOP-BESCHLÄGE | FERRURES TOP

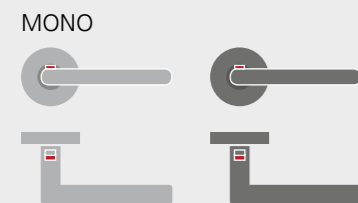

WÄHLBAR IN EDELSTAHL MATT ODER GRAPHITSCHWARZ  
DISPONIBLE EN ACIER INOXYDABLE MAT OU NOIR GRAPHITE

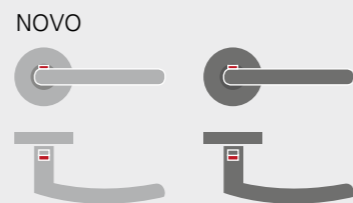

WÄHLBAR IN EDELSTAHL MATT ODER GRAPHITSCHWARZ  
DISPONIBLE EN ACIER INOXYDABLE MAT OU NOIR GRAPHITE

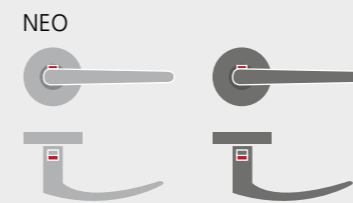

WÄHLBAR IN EDELSTAHL MATT ODER GRAPHITSCHWARZ  
DISPONIBLE EN ACIER INOXYDABLE MAT OU NOIR GRAPHITE

ARBONIA Griffwerk

\*Nicht als Ganzglastür oder LA4, LA5 erhältlich  
\*Non disponible pour les portes tout-verre ou LA4, LA5



## Klimastabilität | Stabilité climatique

Damit die Tür gerade bleibt | Évite la déformation des portes



## Mechanische Beanspruchung Sollicitation mécanique

Damit die Tür was aushält | Offre plus de résistance



## Schallschutz | Protection acoustique

Ruhe bitte | Silence, svp !



## Feuerschutz | Coupe-Feu

Wärmstens empfohlen | Chaudement recommandée



## Feuchtraum | Locaux humides

Mehr Spass durch geprüfte Qualität | Résistante à l'humidité

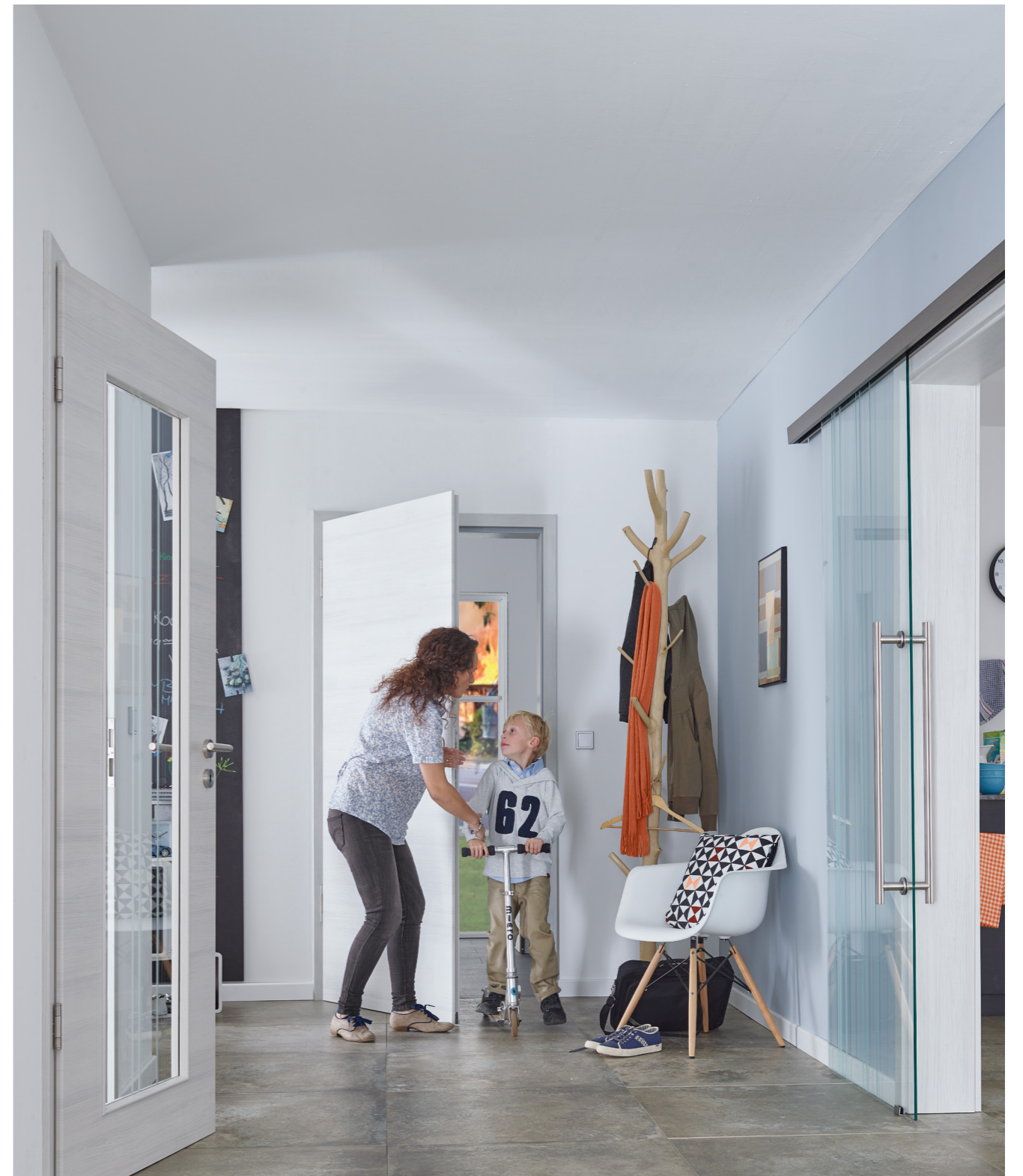

## Feuerschutz | Coupe-Feu

Wärmstens empfohlen | Chaudement recommandée

# Technische Details

## Détails techniques

### ENTDECKEN SIE UNSERE TÜRENDETAILS AUF EINEN BLICK

Eine Übersicht über Glasprogramm, Beschläge, Zargen und spezielle Funktionen.

### VUE D'ENSEMBLE DES DÉTAILS NOS PORTES

Un aperçu de la gamme de verres, des ferrures, des châssis et des fonctions spéciales

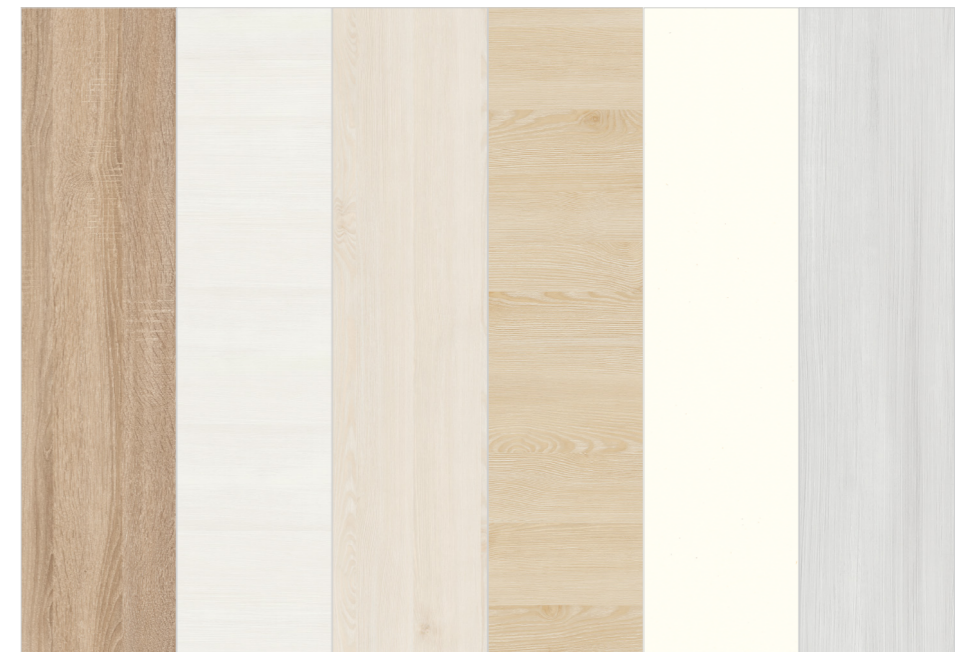

# Ornamentglas für Lichtausschnitt-Türen

## Verre imprimé pour portes vitrées

Wählen Sie Transparenz.  
Choisissez la transparence.

**Arbonia-Designverbund**  
Ornamentgläser als Ganzglastür u.  
Lichtausschnittgläser erhältlich.

**Design composite Arbonia**  
Verre imprimé disponible pour portes  
tout-verre et portes vitrées.

\* nicht als Ganzglas erhältlich  
\* non disponible pour les portes tout-verre



CHINCHILLA WEISS  
CHINCHILLA BLANC



KATHEDRAL WEISS\*  
KATHEDRAL BLANC\*

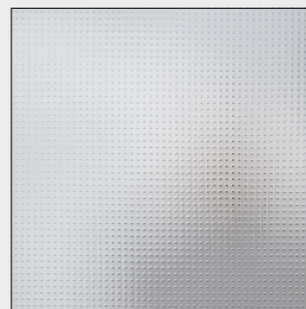

MASTERCARRÉ WEISS  
MASTERCARRÉ BLANC



GOTHIK WEISS\*  
GOTHIK BLANC\*



SILVIT 178 WEISS\*  
SILVIT 178 BLANC\*



UADI WEISS\*  
UADI BLANC\*



FLOAT KLAR  
FLOAT CLAIR

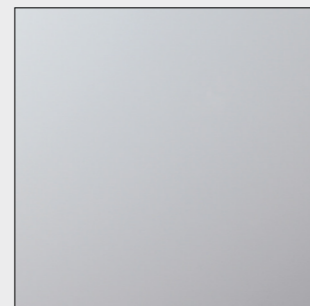

FLOAT SATINIERT  
FLOAT SATINÉ

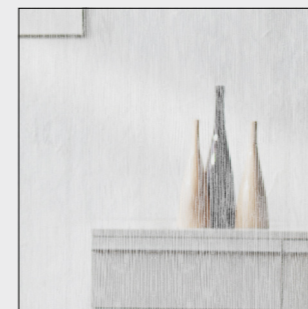

WOOD1-DA



WOOD1-DQ

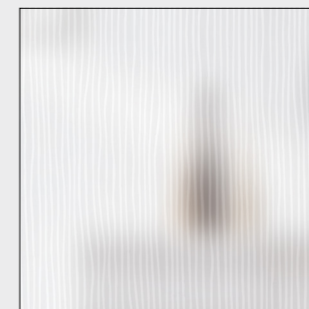

WOOD2-DA



WOOD2-DQ

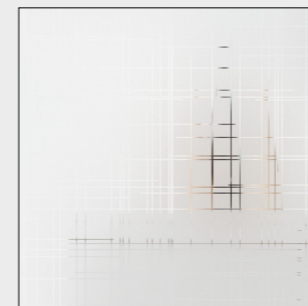

PANNO



PETALI



LIGNO

# Designglas für Lichtausschnitt-Türen

## Verre design pour portes vitrées

Weil ich einzigartigen Durchblick will.  
Pour un visuel unique.

**Arbonia-Designverbund**  
Designglas motive als Ganzglastür  
und Lichtausschnittgläser  
erhältlich.

**Design composite Arbonia**  
Motifs de verre design disponibles  
pour portes tout-verre et portes  
vitrées.

\* nicht als Ganzglas erhältlich  
\* non disponible pour les portes tout-verre

### LASER-VEREDELUNG FINITION AU LASER

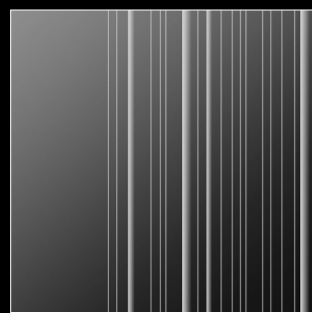

ARPA

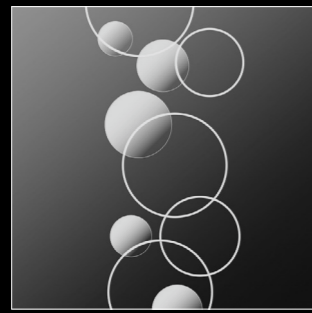

PALLA



FIORE

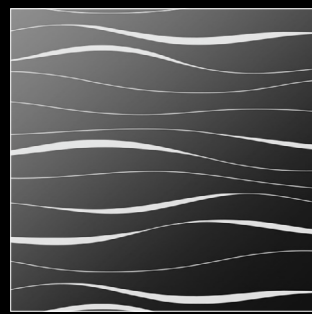

ONDA 1

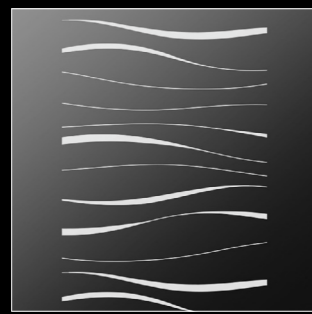

ONDA 2

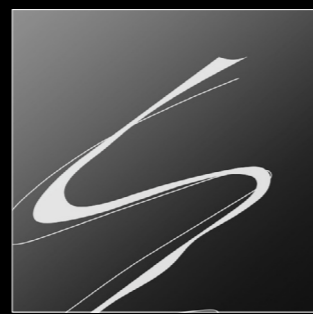

MOTUS



FLORA 1



FLORA 2

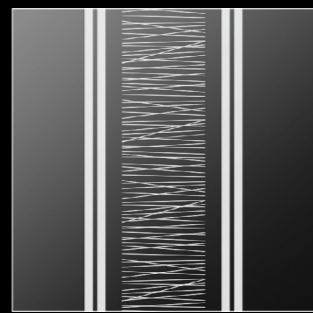

CEN-  
TRO

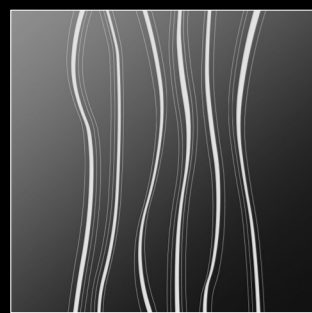

SAGI

### SIEBDRUCK-VEREDELUNG FINITION SÉRIGRAPHIÉE

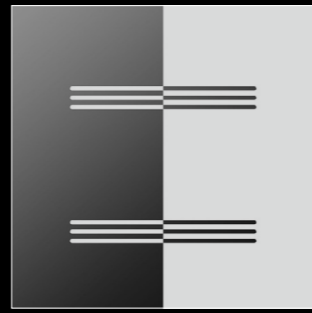

LINEUM



LINEA 1

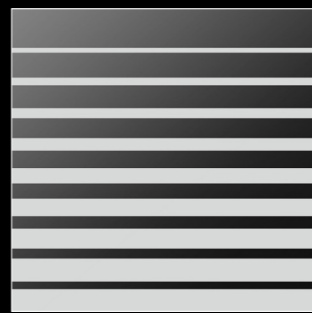

LINO 1

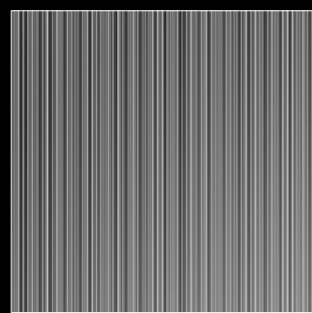

STRIPES-DA

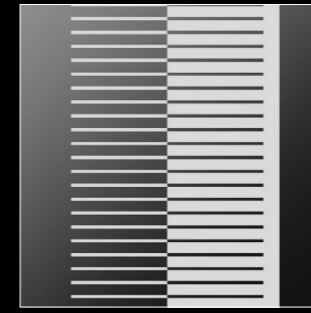

LINUS

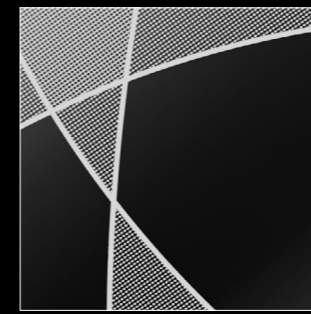

LIPSO

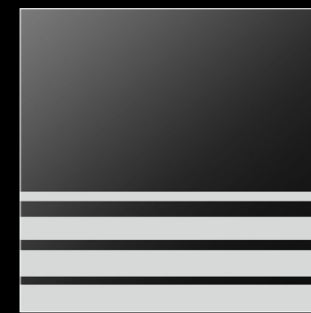

LINO 2

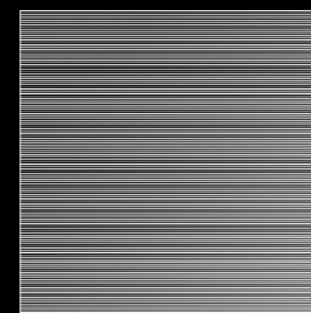

STRIPES-DQ



SEVENTY

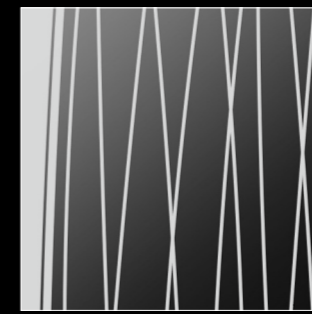

ACCORDIA



DUO 151-1

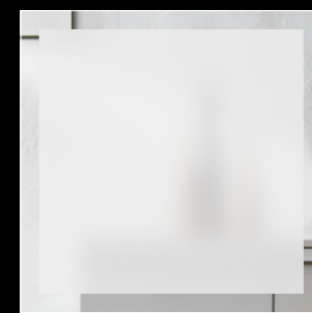

BORDO\*

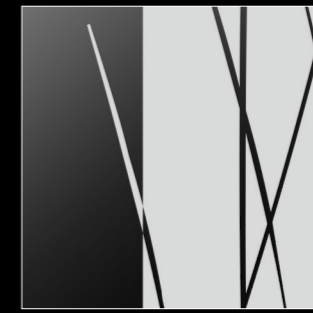

BAMBUS

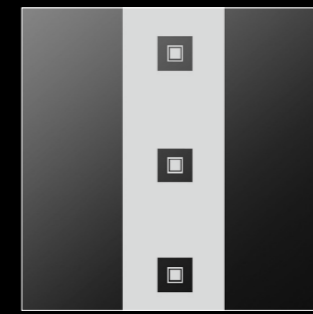

LUCCA

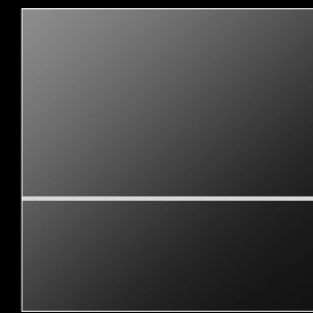

DUO 151-2

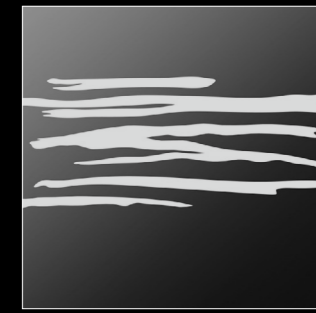

FREE

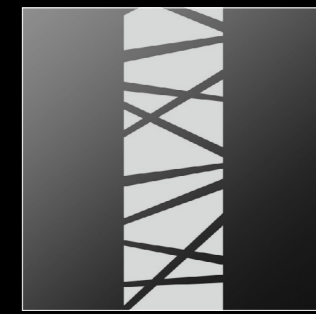

MIKADO 104-1

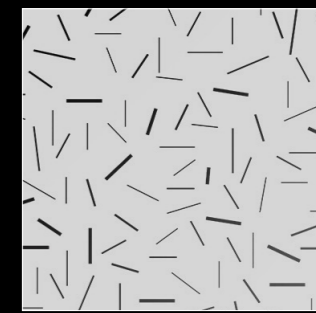

STRATO



TOP

STYLE

PREMIUM

# Beschlagsvielfalt in Stil und System

## Différents styles et systèmes de ferrures

### TÜRGRIFFE UND ZUBEHÖR FÜR ALLE ANWENDUNGEN

Türbeschläge sind ein prägendes Stilelement der Tür und unterstreichen die architektonische Note des Raums. Unser umfassendes Sortiment bietet eine Vielzahl an Designs und für jede Anforderung die passende Lösung: vom Türgriff, über das Glastürschloss bis hin zu passenden Bändern.

### POIGNÉES DE PORTE ET ACCESSOIRES POUR TOUTES LES APPLICATIONS

Les ferrures de porte sont un élément important de toute porte et soulignent la note architecturale de la pièce. Notre gamme complète propose une multitude de designs et une solution adaptée à chaque exigence : de la poignée de porte aux paumelles assorties, en passant par la serrure de porte en verre.

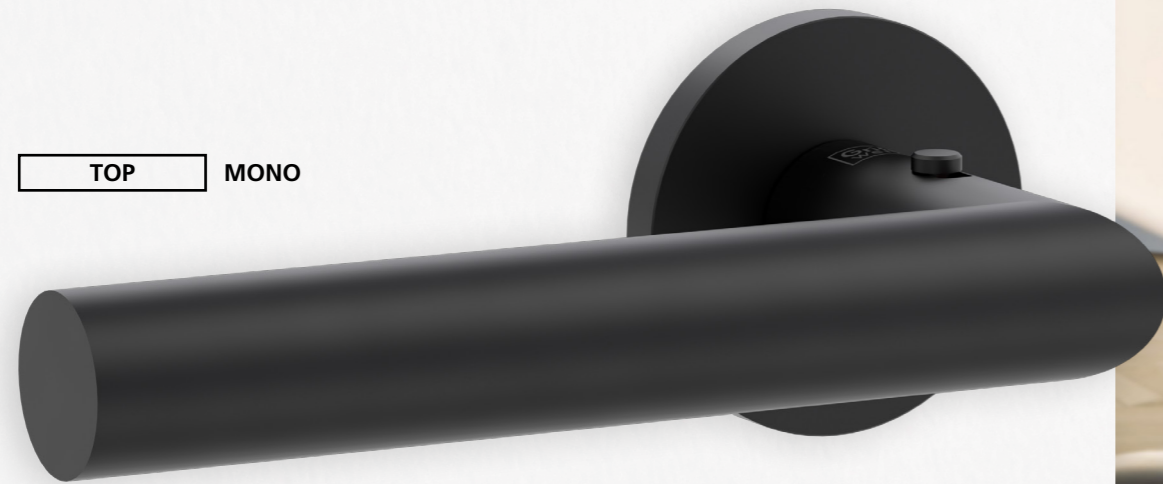

TOP MONO



ARBONIA ▲

Griffwerk

TOP

MONO



MONO BB  
Schnellmontagetechnik | Graphitschwarz  
Technique de montage rapide | Noir graphite



MONO BB  
Schnellmontagetechnik | Edelstahl matt  
Technique de montage rapide | Acier inoxydable mat

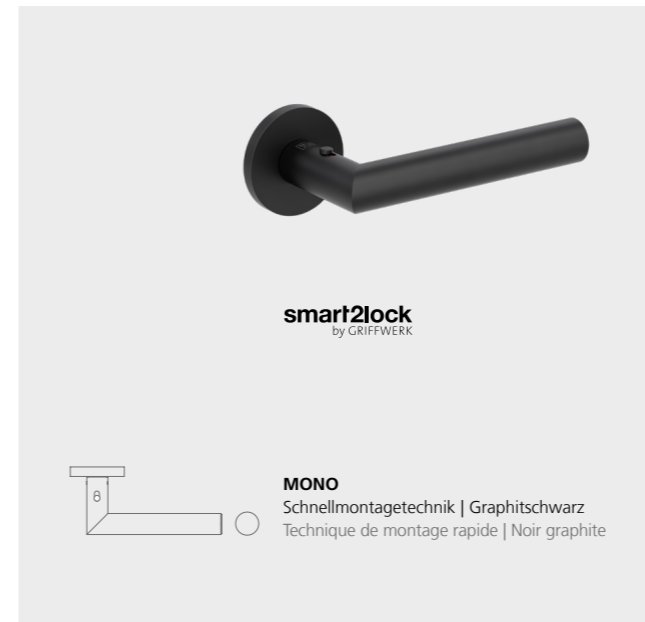

smart2lock  
by GRIFFWERK

MONO  
Schnellmontagetechnik | Graphitschwarz  
Technique de montage rapide | Noir graphite

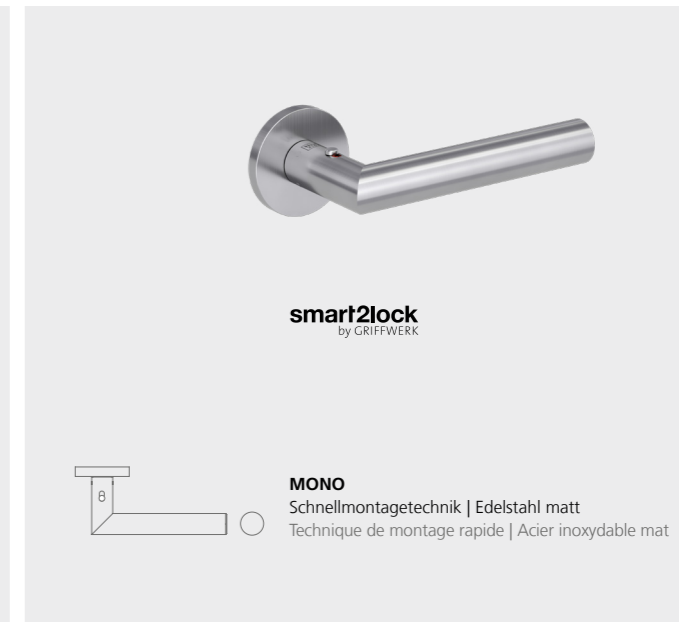

smart2lock  
by GRIFFWERK

MONO  
Schnellmontagetechnik | Edelstahl matt  
Technique de montage rapide | Acier inoxydable mat

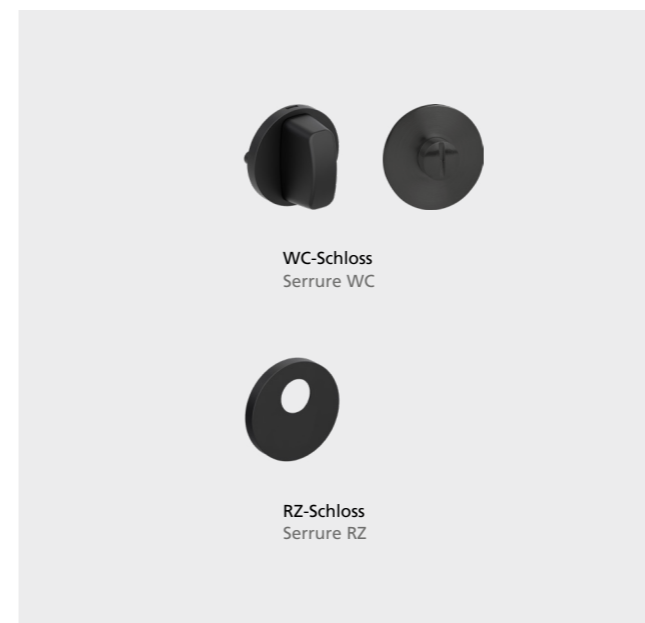

WC-Schloss  
Serrure WC

RZ-Schloss  
Serrure RZ

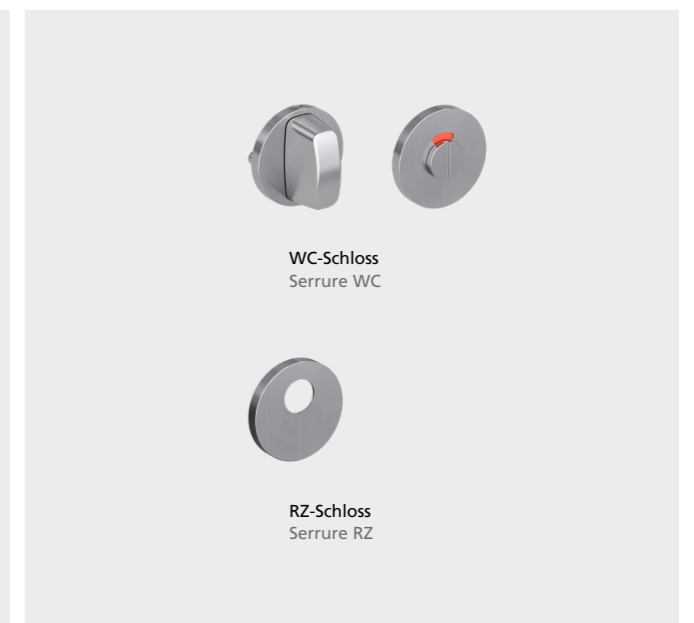

WC-Schloss  
Serrure WC

RZ-Schloss  
Serrure RZ

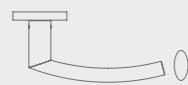

**NOVO BB**  
Schnellmontagetechnik | Graphitschwarz  
Technique de montage rapide | Noir graphite



**NOVO BB**  
Schnellmontagetechnik | Edelstahl matt  
Technique de montage rapide | Acier inoxydable mat



**smart2lock**  
by GRIFFWERK



**NOVO**  
Schnellmontagetechnik | Graphitschwarz  
Technique de montage rapide | Noir graphite



**smart2lock**  
by GRIFFWERK



**NOVO**  
Schnellmontagetechnik | Edelstahl matt  
Technique de montage rapide | Acier inoxydable mat



**WC-Schloss**  
Serrure WC



**RZ-Schloss**  
Serrure RZ



**WC-Schloss**  
Serrure WC



**RZ-Schloss**  
Serrure RZ



**NEO BB**  
Schnellmontagetechnik | Graphitschwarz  
Technique de montage rapide | Noir graphite

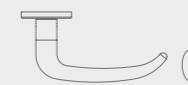

**NEO BB**  
Schnellmontagetechnik | Edelstahl matt  
Technique de montage rapide | Acier inoxydable mat



**smart2lock**  
by GRIFFWERK

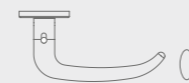

**NEO**  
Schnellmontagetechnik | Graphitschwarz  
Technique de montage rapide | Noir graphite

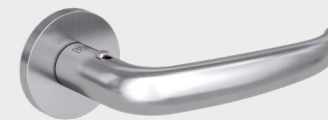

**smart2lock**  
by GRIFFWERK

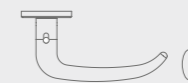

**NEO**  
Schnellmontagetechnik | Edelstahl matt  
Technique de montage rapide | Acier inoxydable mat



**WC-Schloss**  
Serrure WC

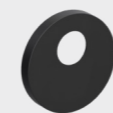

**RZ-Schloss**  
Serrure RZ



**WC-Schloss**  
Serrure WC



**RZ-Schloss**  
Serrure RZ

**STANGENGRIF ECKIG**  
 POIGNÉE-BARRE  
 ANGULAIRE

Paar zur beidseitigen oder als Stück zur einseitigen Türbetätigung

Paire pour actionner la porte des deux côtés ou pièce unique pour actionner la porte d'un seul côté

L: 400 mm

L: 800 mm

L: 1200 mm

**STANGENGRIF RUND**  
 POIGNÉE-BARRE  
 RONDE

L: 400 mm

L: 800 mm

L: 1200 mm

**STANGENGRIF FÜR KOMPLETTÖFFNUNG**

Varianten mit 10 mm Griffleiste in Ausführungen Länge 400 mm, 800 mm und 1200 mm in Edelstahl Matt für Ganzglastüren erhältlich. Auch als Variante „einseitig Flachschieberosette“ erhältlich.



**POIGNÉE-BARRE POUR OUVERTURE COMPLÈTE**  
 Variantes avec baguette de poignée de 10 mm en versions 400 mm, 800 mm et 1200 mm de long disponibles en acier inoxydable mat pour les portes tout verre. Également disponible en variante « rosace coulissante plate d'un côté ».

L: 400 mm/800 mm/1200 mm

**KLEBESCHLÄGE**

Beschläge für Ganzglas-Schiebetüren in Edelstahl Mattoptik

**FERRURES ADHÉSIVES**

Ferrures pour portes coulissantes en verre avec aspect acier inoxydable



**Klebe-Griffstange**  
 Barre-poignée adhésive  
 L: 400 mm



**Klebe-Griffleisten**  
 Baguettes de poignée adhésives  
 L: 200 mm/400 mm

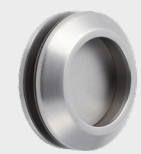

**Griffmuschel rund für Ganzglastüren**  
 Poignée encastrée ronde pour portes tout verre



**Griffmuschel rund für Holztüren**  
 Poignée encastrée ronde pour portes en bois



**Griffmuschel eckig für Holz- und Ganzglastüren**  
 Poignée encastrée carrée pour portes tout verre et en bois



**Klebe-Griffmuschel rund für Ganzglastüren**  
 Poignée coquille adhésive ronde pour portes en verre



**Klebe-Griffmuschel eckig für Ganzglastüren**  
 Poignée coquille adhésive carrée pour portes en verre

**STANGENGRIF ECKIG**  
 POIGNÉE-BARRE  
 ANGULAIRE

Paar zur beidseitigen oder als Stück zur einseitigen Türbetätigung

Paire pour actionner la porte des deux côtés ou pièce unique pour actionner la porte d'un seul côté

L: 400 mm

L: 800 mm

L: 1200 mm

**STANGENGRIF RUND**  
 POIGNÉE-BARRE  
 RONDE

L: 400 mm

L: 800 mm

L: 1200 mm

**STANGENGRIF FÜR KOMPLETTÖFFNUNG**

Varianten mit 10 mm Griffleiste in Ausführungen Länge 400 mm, 800 mm und 1200 mm in Schwarz Matt für Ganzglastüren erhältlich. Auch als Variante „einseitig Flachschieberosette“ erhältlich.



**POIGNÉE-BARRE POUR OUVERTURE COMPLÈTE**  
 Variantes avec baguette de poignée de 10 mm en versions 400 mm, 800 mm et 1200 mm de long disponibles en acier inoxydable mat pour les portes tout verre. Également disponible en variante « rosace coulissante plate d'un côté ».

L: 400 mm/800 mm/1200 mm

**KLEBESCHLÄGE**

Beschläge für Ganzglas-Schiebetüren in schwarz

**FERRURES ADHÉSIVES**

Ferrures pour portes coulissantes en verre avec noir



**Klebe-Griffstange**  
 Barre-poignée adhésive  
 L: 400 mm



**Klebe-Griffleisten**  
 Baguettes de poignée adhésives  
 L: 200 mm/400 mm

\*ähnlich RAL9005 \*similaire à RAL9005



**Griffmuschel rund für Holztüren**  
 Poignée encastrée ronde pour portes en bois



**Klebe-Griffmuschel rund für Ganzglastüren**  
 Poignée coquille adhésive ronde pour portes en verre



**Klebe-Griffmuschel eckig für Ganzglastüren**  
 Poignée coquille adhésive carrée pour portes en verre

# Windfangelemente und Schiebetürlösungen Éléments coupe-vent et solutions de portes coulissantes



Windfangelemente und Schiebetürlösungen



## **SCHIEBETÜRBESCHLAG SLIM**

Das schlanke Schiebetürsystem im Edelstahl-Design für Holz- und Ganzglastüren. SLIM ist wahlweise auch mit Einzugsdämpfung (beidseitig) lieferbar.

## **FERRURE POUR PORTE COULISSANTE SLIM**

Le système de porte coulissante fin en design acier pour portes en bois et entièrement vitrées. SLIM est aussi disponible au choix avec amortisseur de butée (sur deux côtés).



## **SCHIEBETÜRBESCHLAG KLASSE – AUSFÜHRUNG „VOR DER WAND LAUFEND“**

Die gehobene Holzklasse, unser KLASSE-Schiebetürbeschlag für Holz- und Ganzglastüren. Öffnen Sie Türen auf die klassische Art. KLASSE ist wahlweise auch mit Einzugsdämpfung (ein- oder beidseitig) lieferbar.

## **FERRURE POUR PORTE COULISSANTE KLASSE – AGENCEMENT «DEVANT LE MUR»**

Le bois gagne en élégance avec nos ferrures KLASSE pour portes coulissantes bois et entièrement vitrées. Ouvrez les portes de façon classique. KLASSE est aussi disponible au choix avec amortisseur de butée (sur un ou deux côtés).

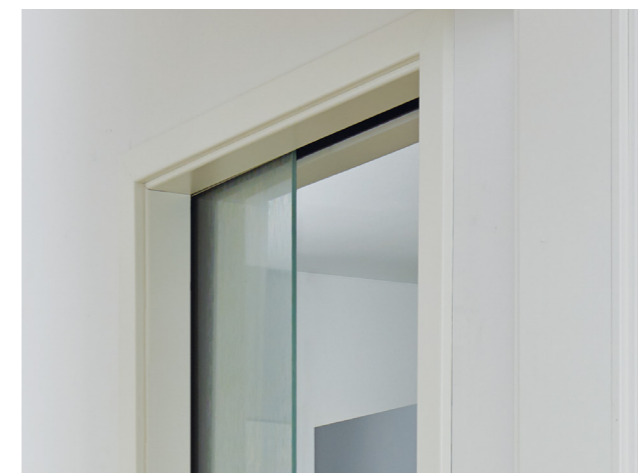

## **SCHIEBETÜRBESCHLAG KLASSE – AUSFÜHRUNG „IN DER WAND LAUFEND“**

Innenlaufende Schiebetüren mit dem KLASSE-Schiebetürbeschlag – egal ob als Holz- oder Ganzglastüren – sind die ideale Lösung, wenn es für normale Drehtüren in den verbundenen Räumen keinen Öffnungs- und Bewegungsraum gibt.

## **FERRURE POUR PORTE COULISSANTE KLASSE – AGENCEMENT «DANS LE MUR»**

Les portes coulissantes à galandage en bois ou entièrement vitrées dotées de la ferrure adaptée KLASSE constituent la solution idéale lorsque l'espace d'ouverture et de mouvement est insuffisant pour des portes pivotantes dans les pièces communicantes.

# Schiebetürbeschlag SLIM

## Ferrure de porte coulissante SLIM

Platzsparendes Design auch für kleine Räume.  
Gain de place même pour les petites pièces.



### SCHIEBETÜRBESCHLAG SLIM

Das schlanke Schiebetürsystem im Edelstahl-Design für Holz- und Ganzglastüren. SLIM ist wahlweise auch mit Einzugsdämpfung (beidseitig) lieferbar.



### FERRURE POUR PORTE COULISSANTE SLIM

Le système de porte coulissante fin au design en acier inoxydable pour les portes en bois et tout verre. SLIM est également disponible au choix avec amortisseur de butée (des deux côtés).



SLIM mit Anschlagkasten  
SLIM avec caisson de butée



Befestigung Holztür bei SLIM  
Fixation pour porte en bois avec SLIM

# SLIM-Schiebetürbeschlag mit Inlay

## Ferrure de porte coulissante SLIM avec Inlay

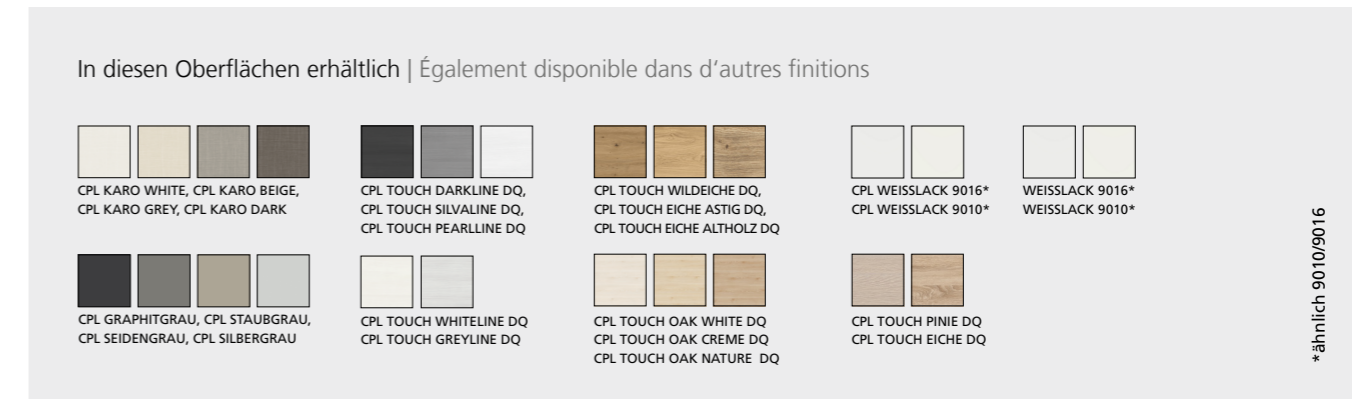

Befestigung Ganzglastür bei SLIM-Inlay  
Fixation pour porte en verre avec inlay SLIM



SLIM ohne Anschlagkasten  
SLIM sans caisson de butée

# Schiebetürbeschlag KLASSIK

## Ferrure de porte coulissante KLASSIK

Platzsparendes Design auch für kleine Räume.  
Gain de place même pour les petites pièces.



KLASSIK mit Anschlagkasten  
ohne Türfutter  
avec caisson de butée, sans cadre



KLASSIK ohne Anschlagkasten  
mit Türfutter  
sans caisson de butée, avec cadre

Die klassische Variante für Schiebetüren:  
Der obere Laufkasten – farb- und dekor-  
gleich zur verwendeten Zarge – versteckt  
gekonnt den Schiebemechanismus. Mit  
dem vorderen Anschlagkasten wird der  
optionale Einsatz eines Schlosses möglich.

La variante classique des portes coulissantes : le caisson supérieur au coloris identique au châssis utilisé dissimule habilement le mécanisme de coulissement. Avec le caisson de butée avant, il est également possible d'utiliser une serrure.



# Innenlaufende Schiebetüren

## Portes coulissantes à galandage

Platzsparendes Design auch für kleine Räume.  
Gain de place même pour les petites pièces.

### INNENLAUFENDE SCHIEBETÜREN ALS GANZGLASTÜREN

Innenlaufende Schiebetürenelemente mit dem KLASSIK-Schiebetürbeschlag für Ganzglastüren sind die ideale Lösung, wenn es für herkömmliche Ganzglastüren als Drehtüren in den verbundenen Räumen keinen Öffnungs- und Bewegungsraum gibt.

### PORTES COULISSANTES À GALANDAGE TOUT VERRE

Les éléments de portes coulissantes à galandage dotées de la ferrure KLASSIK pour portes coulissantes tout-verre sont la solution idéale lorsqu'il n'y a pas suffisamment d'espace pour ouvrir une porte pivotante traditionnelle entre des pièces communicantes.

### INNENLAUFENDE SCHIEBETÜREN ALS HOLZTÜREN

Innenlaufende Schiebetürenelemente mit dem KLASSIK-Schiebetürbeschlag für Holztüren sind die ideale Lösung, wenn es keinen Platz für herkömmliche Drehtürsysteme gibt.

### PORTES COULISSANTES À GALANDAGE EN BOIS

Les éléments de portes coulissantes à galandage dotées de la ferrure KLASSIK pour portes coulissantes en bois sont la solution idéale lorsqu'il n'y a pas suffisamment d'espace pour les systèmes classiques de porte pivotante.



# Breite Zargenbekleidungen machen den Unterschied Des cadres et faux cadres larges pour faire la différence

Verbessern auch Sie die Optik Ihrer Türen durch breitere Zargenbekleidungen!  
Améliorez également l'esthétique de vos portes grâce à des cadres et faux-cadres plus larges !

**80 mm Bekleidungsbreite – 22 mm Bekleidungsstärke**  
**Die perfekte Renovierungszarge!**  
Ideal für ungenaue Maueröffnungen sowie passgenaue Fussleistenanschlüsse. Und auch optisch ein echtes Highlight!

**Largeur du cadre et faux-cadre de 80 mm, épaisseur de 22 mm**  
**Le châssis parfait pour les travaux de rénovation !**  
Idéal pour les ouvertures murales inégales et les raccords de plinthes ajustés. Un véritable atout esthétique !

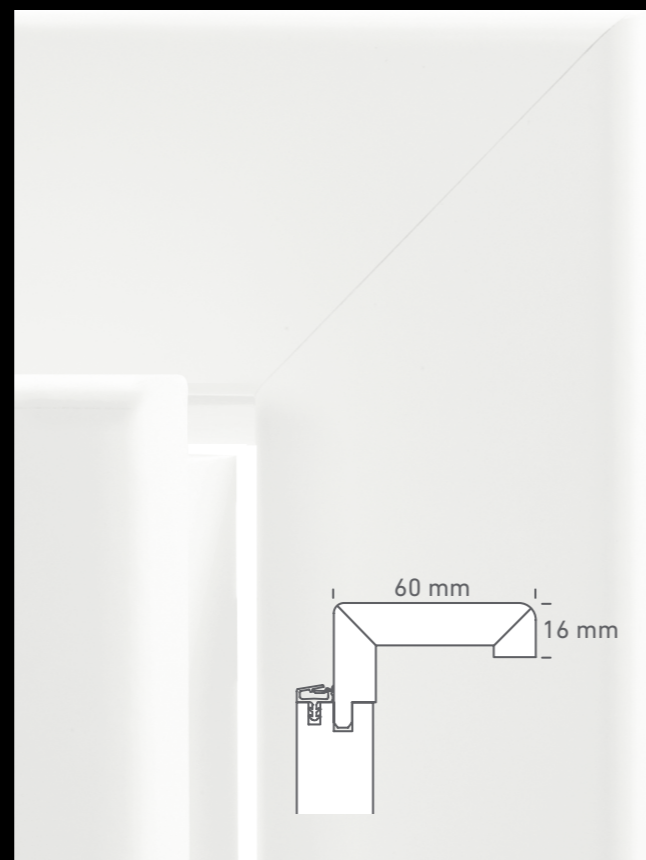
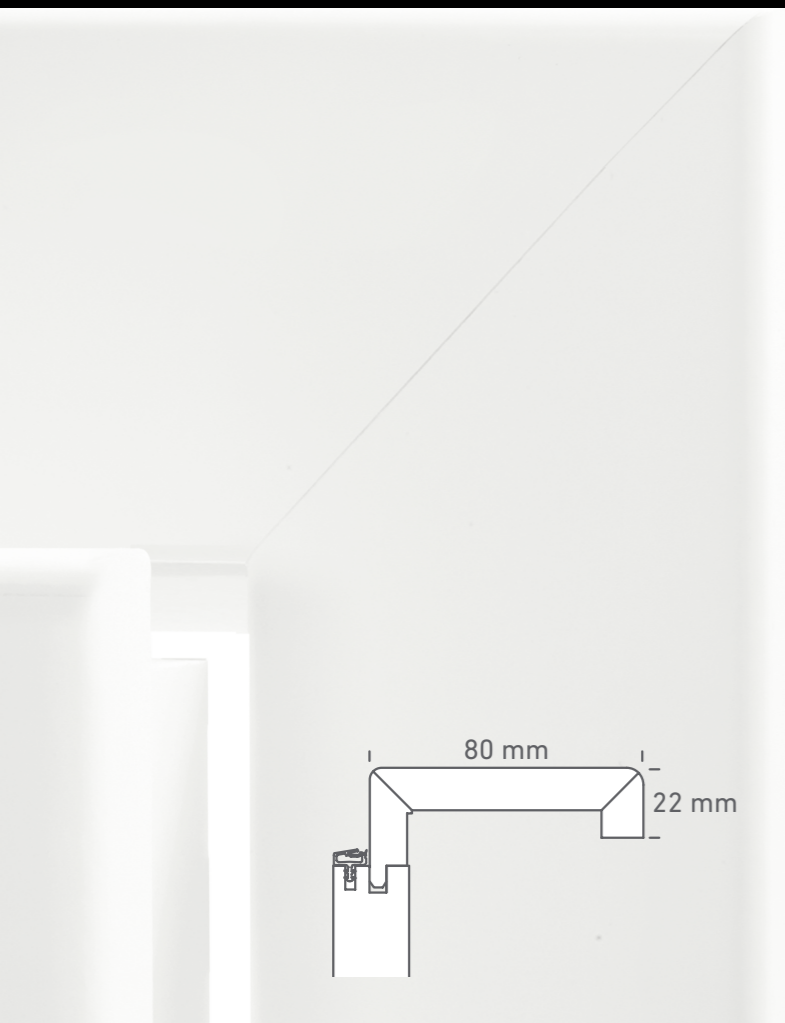

## MÖGLICHE AUSFÜHRUNGEN

- Ausführung STUMPF und GEFÄLZT möglich
- Runde Kantenform bei CPL und Weisslack 9010
- Auch als EC 80/22 mm (Weisslack 9010) und KR 80/22 (Weisslack 9016) möglich
- Ab Wandstärke 80 mm lieferbar (stumpf ab 100 mm)
- Verstärkt durch doppelte Eckverbinder
- Größere Umkantung für bessere Mauerstärkentoleranz
- Kombinierbar mit Schiebetürbeschlag KLASSIK und SLIM
- FEUERSCHUTZ objektbezogen ab 20 Elementen

## FINITIONS POSSIBLES

- Finitions afileurées et à recouvrement possibles
- Chants arrondis sur stratifié CPL et blace laqué 9010
- Également disponible en EC 80/22 mm (blace laqué 9010) et KR 80/22 (blace laqué 9016) possible
- Disponible à partir d'une épaisseur de mur de 80 mm (Chant afileuré > 100 mm)
- Renforcé par des doubles raccords d'angles
- Retour sur mur plus important pour une meilleure tolérance d'épaisseur
- Convient également aux ferrures de portes coulissantes KLASSIK et SLIM
- Protection anti-feu, en fonction de l'objet à partir de 20 éléments

**ZARGE: 80 MM BEKLEIDUNG**  
**CHÄSSIS: CADRE ET FAUX-CADRE DE 80 MM**



**ZARGE: 60 MM BEKLEIDUNG**  
**CHÄSSIS: CADRE ET FAUX-CADRE DE 60 MM**

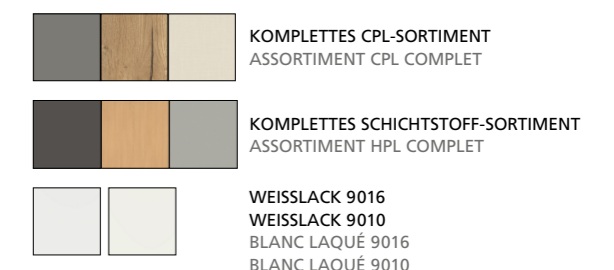

ECKIG  
CHANT DROIT

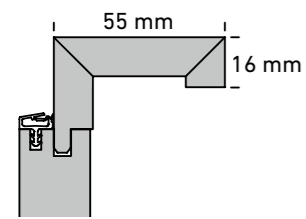

FU-EC-55/16



WEISSLACK 9010  
BLANC LAQUÉ 9010

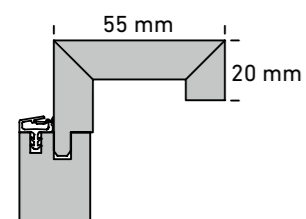

FU-EC-55/20



SCHICHTSTOFF-SORTIMENT  
ASSORTIMENT STRATIFIÉ

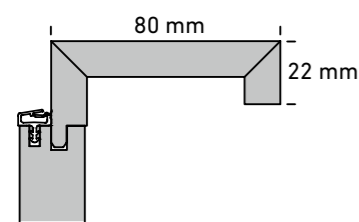

FU-EC-80/22



WEISSLACK 9010  
BLANC LAQUÉ 9010

RUND  
CHANT ARRONDI

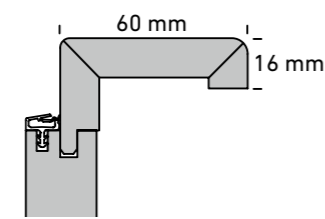

FU-RF-60/16



WEISSLACK 9010  
BLANC LAQUÉ 9010



CPL-SORTIMENT  
ASSORTIMENT CPL

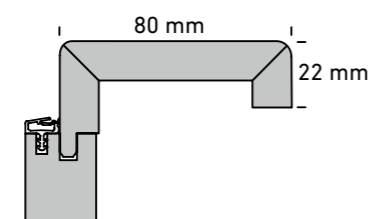

FU-RF-80/22



WEISSLACK 9016, WEISSLACK 9010  
BLANC LAQUÉ 9016, BLANC LAQUÉ 9010



CPL TOUCH EICHE ALHOLZ, CPL TOUCH WILDEICHE,  
CPL TOUCH OAK WHITE, CPL TOUCH OAK CREME,  
CPL TOUCH OAK NATURE  
CPL TOUCH VIEUX BOIS DE CHÊNE, CPL TOUCH CHÊNE  
SAUVAGE, CPL TOUCH OAK WHITE, CPL TOUCH OAK  
CREME, CPL TOUCH OAK NATURE



CPL WEISSLACK 9010, CPL TOUCH WHITELINE,  
CPL TOUCH GREYLINE  
CPL BLANC LAQUÉ 9010, CPL TOUCH WHITELINE,  
CPL TOUCH GREYLINE

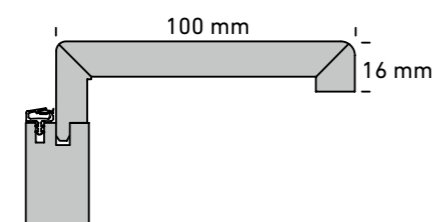

FU-RF-100/16



WEISSLACK 9010  
BLANC LAQUÉ 9010

KLEINE RUNDKANTE  
PETIT CHANT ARRONDI

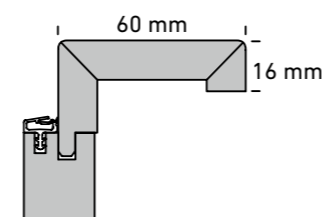

FU-RFKR-60/16



WEISSLACK 9016  
BLANC LAQUÉ 9016



CPL WEISSLACK 9016  
CPL BLANC LAQUÉ 9016

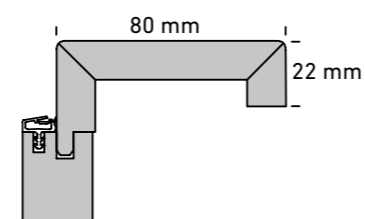

FU-RFKR-80/22



WEISSLACK 9016  
BLANC LAQUÉ 9016

PROFILIERT  
PROFIL MOULURÉ

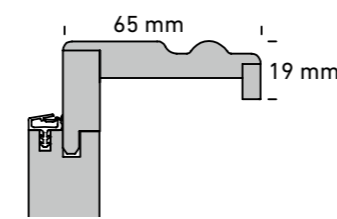

FU-PR-65/19



WEISSLACK 9010  
BLANC LAQUÉ 9010

SOFTLINE  
SOFTLINE

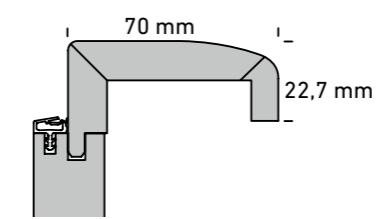

FU-SLF-70/16



WEISSLACK 9010  
BLANC LAQUÉ 9010

PRIMO  
PRIMO

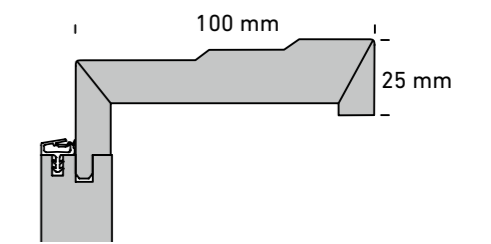

FU-PRIMO-100/25



WEISSLACK 9016, WEISSLACK 9010  
BLANC LAQUÉ 9016, BLANC LAQUÉ 9010



# Mit Idealmass auf Ihrer Linie

## Des mesures adaptées à vos besoins

### Wohnraumtürelement mit Serienzarge Futter rund gefälzt

Élément de portes avec cadre, faux-cadre et embrasure, chant arrondi et feuillure, pour portes à recouvrement.

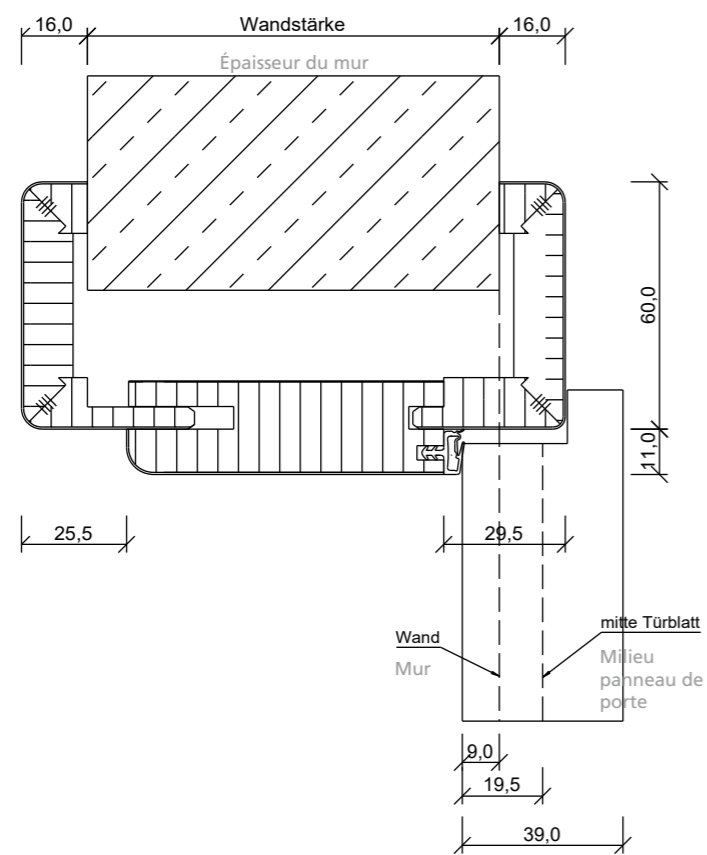

Wandstärke [mm] Épaisseur de mur [mm]	Verstellbereich [mm] Plage de réglage [mm]	Abdeckung [mm] Recouvrement [mm]
50	-3,0/+5,0	47 bis 55
60	-5,0/+5,0	55 bis 65
70	-5,0/+5,0	65 bis 75
80	-5,0/+15,0	75 bis 95
100	-5,0/+15,0	95 bis 115
125	-10,0/+10,0	115 bis 135
145	-10,0/+10,0	135 bis 155

Wandstärke [mm] Épaisseur de mur [mm]	Verstellbereich [mm] Plage de réglage [mm]	Abdeckung [mm] Recouvrement [mm]
165	-10,0/+10,0	155 bis 175
185	-10,0/+10,0	175 bis 195
205	-10,0/+10,0	195 bis 215
245	-10,0/+10,0	235 bis 255
270	-10,0/+10,0	260 bis 280
290	-10,0/+10,0	280 bis 300
330	-10,0/+10,0	320 bis 340

### Wohnraumtürelement mit Serienzarge Futter rund stumpf

Élément de portes avec cadre, faux-cadre et embrasure, chant arrondi et feuillure, pour portes affleurées.

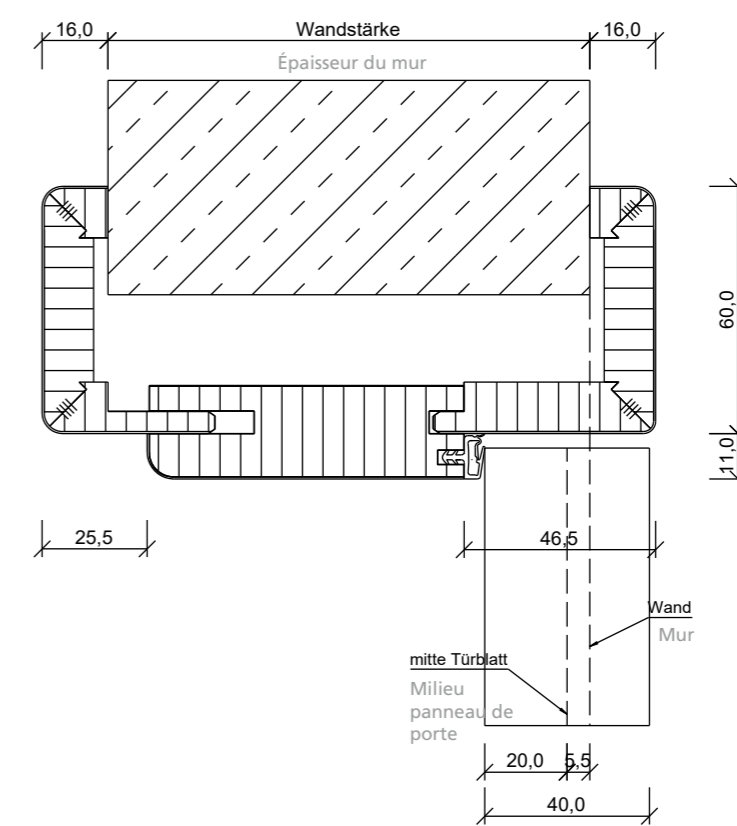

Wandstärke [mm] Épaisseur de mur [mm]	Verstellbereich [mm] Plage de réglage [mm]	Abdeckung [mm] Recouvrement [mm]
100	-5,0/+15,0	95 bis 115
125	-10,0/+10,0	115 bis 135
145	-10,0/+10,0	135 bis 155
165	-10,0/+10,0	155 bis 175
185	-10,0/+10,0	175 bis 195

Wandstärke [mm] Épaisseur de mur [mm]	Verstellbereich [mm] Plage de réglage [mm]	Abdeckung [mm] Recouvrement [mm]
205	-10,0/+10,0	195 bis 215
245	-10,0/+10,0	235 bis 255
270	-10,0/+10,0	260 bis 280
290	-10,0/+10,0	280 bis 300
330	-10,0/+10,0	320 bis 340

SCHWEIZER MASSE: TÜRFUTTER FÜR 1- UND 2-FLÜGELIGE GEFÄLTZE TÜRBLÄTTER

Table with columns: Massgruppe, Einflügelige Türen, Zweiflügelige Türen, and various dimensions (b1, h1, b2, h2, b3, h3, b4, h4, b5, h5, min., max.).

Bandtasche trägt ca. 14 mm auf.

SCHWEIZER MASSE: TÜRFUTTER FÜR 1- UND 2-FLÜGELIGE STUMPFE TÜRBLÄTTER

Table with columns: Massgruppe, Einflügelige Türen, Zweiflügelige Türen, and various dimensions (b1, h1, b2, h2, b3, h3, b4, h4, b5, h5, min., max.).

Bitte berücksichtigen Sie, dass die Bandtasche noch aufträgt. Weitere Informationen auf Anfrage.



3-teiliges Band (stumpfen Türen) V7888



Verdeckte Bänder (stumpfen Türen) TECTUS 340



2-tlg. Band (gefälzte Türen) V3420



3-tlg. Band (gefälzte Türen) V4426

TABLEAU DES DIMENSIONS SUISSES : CADRE, FAUX-CADRE, EMBRASURE, POUR PORTES À RECOUVREMENT 1 ET 2 VANTAUX

Table with columns: Aperçu des dimensions, Portes à un vantail, Portes à deux vantaux, and various dimensions (b1, h1, b2, h2, b3, h3, b4, h4, b5, h5, min., max.).

Épaisseur du logement de paumelle : environ 14 mm

TABLEAU DES DIMENSIONS SUISSES : CADRE, FAUX-CADRE, EMBRASURE, POUR PORTES AFFLEURÉES 1 ET 2 VANTAUX

Table with columns: Aperçu des dimensions, Portes à un vantail, Portes à deux vantaux, and various dimensions (b1, h1, b2, h2, b3, h3, b4, h4, b5, h5, min., max.).

Veillez prendre en compte que le logement de Hauteur d'ouverture du mur s'ajoute à l'épaisseur de la dimension extérieure de l'embrasure. Pour plus d'information, n'hésitez pas à nous contacter.



Paumelle en 3 parties (porte affleurée) V7888



Paumelle invisible (porte affleurée) TECTUS 340



Paumelle en 2 parties (porte à recouvrement) V3420



Paumelle en 3 parties (porte à recouvrement) V4426

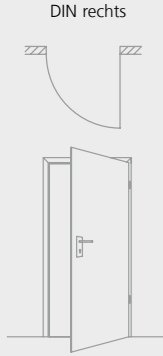

DIN rechts

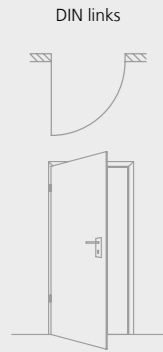

DIN links

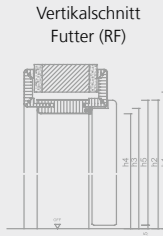

Vertikalschnitt Futter (RF)



Horizontalschnitt Futter (RF) 1-flügelig gefälzte Türen



Horizontalschnitt Futter (RF) 2-flügelig gefälzte Türen

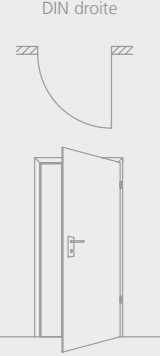

DIN droite

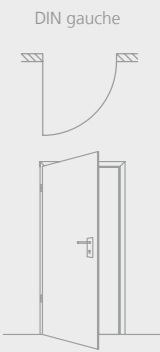

DIN gauche

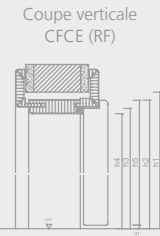

Coupe verticale CFCE (RF)



Coupe transversale CFCE (RF) Porte un vantail à recouvrement

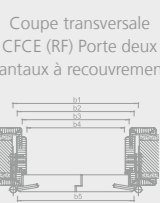

Coupe transversale CFCE (RF) Porte deux vantaux à recouvrement

## STANDARD-TÜRBLÄTTER



### STANDARD-AUSFÜHRUNG

- Band V0020
- Swiss BB

### MÖGLICHE SCHLOSSVARIANTEN

- WC-Schloss, Kaba-Schloss

### MÖGLICHE BANDVARIANTEN

- V0026

### MASSE TÜRBLATT

BREITE	HÖHE
1-flg. 650 / 700 / 750 / 800 / 850 / 900 / 950 / 1000	2015
	2110

Alle Masse in mm \*nur möglich als RS/LA

## PANNEAU DE PORTE STANDARD



### VERSION STANDARD

- Fiche V0020
- Serrure Suisse BB

### VARIANTE DE PAUMELLE POSSIBLE

- V0026

### VARIANTE DE SERRURE POSSIBLE

- Serrure WC, Serrure Kaba

### DIMENSION PANNEAU DE PORTE

LARGEUR	HAUTEUR
1 vantail 650 / 700 / 750 / 800 / 850 / 900 / 950 / 1000	2015
	2110

Toutes les dimensions en mm \*uniquement possible en RS/LA



### STANDARD-AUSFÜHRUNG

- Griffmuschel Edelstahloptik

### MÖGLICHE SCHIEBETÜRBESCHLÄGE

- SLIM mit Türfutter
- SLIM ohne Türfutter
- KLASSIK mit Türfutter

### MASSE SCHIEBETÜRBLATT SLIM UND KLASSIK

BREITE	HÖHE			
1-flg. 650 / 700 / 750 / 800 / 850 / 900 / 950 / 1000	2015 KLASSIK	-	-	-
		2045 SLIM	2110 KLASSIK	2140 SLIM

Alle Masse in mm



### VERSION STANDARD

- Poignée coquille aspect inox

### VARIANTE POSSIBLE

- SLIM avec cadre de passage
- SLIM sans cadre de passage
- KLASSIK avec cadre de passage

### DIMENSION PANNEAU DE PORTE COULISSANT SLIM ET KLASSIK

LARGEUR	HAUTEUR			
1 vantail 650 / 700 / 750 / 800 / 850 / 900 / 950 / 1000	2015 KLASSIK	-	-	-
		2045 SLIM	2110 KLASSIK	2140 SLIM

Alle Masse in mm

## KANTENAUSFÜHRUNGEN



## MITTELAGEN

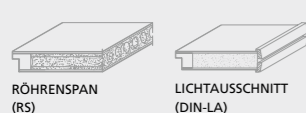

## MODÈLES DE CHANTS



## ÂME DES PANNEAUX



TÜRBLATT, KANTENAUSFÜHRUNGEN UND MITTELAGEN

OBERFLÄCHE	KANTE				MITELLAGE	
	RP	EC	KR	PK2	RS	LA (DIN-LA)
CPL KARO WHITE				X	X	X
CPL KARO BEIGE				X	X	X
CPL KARO GREY				X	X	X
CPL KARO DARK				X	X	X
CPL GRAPHITGRAU			X	X	X	X
CPL STAUBGRAU			X	X	X	X
CPL SEIDENGRAU			X	X	X	X
CPL SILBERGRAU			X	X	X	X
CPL TOUCH DARKLINE DA/DQ			X	X	X	X
CPL TOUCH SILVALINE DA/DQ			X	X	X	X
CPL TOUCH PEARLLINE DA/DQ			X	X	X	X
CPL TOUCH WHITELINE DA/DQ			X	X	X	X
CPL TOUCH GREYLINE DA/DQ			X	X	X	X
CPL TOUCH WILDEICHE DA/DQ			X	X	X	X
CPL TOUCH EICHE ASTIG DA/DQ	X			X	X	X
CPL TOUCH EICHE ALTHOLZ DA/DQ	X			X	X	X
CPL TOUCH OAK WHITE DA/DQ	X			X	X	X
CPL TOUCH OAK CREME DA/DQ	X			X	X	X
CPL TOUCH OAK NATURE DA/DQ	X			X	X	X
CPL TOUCH PINIE DA/DQ	X			X	X	X
CPL TOUCH EICHE DA/DQ	X			X	X	X
CPL AHORN PUR	X			X	X	X
CPL BUCHE PUR	X			X	X	X
CPL ESCHE WEISS (DECKEND)	X			X	X	X
CPL EICHE	X			X	X	X
CPL WEISSLACK 9016*			X	X	X	X
CPL WEISSLACK 9010*	X			X	X	X
WEISSLACK 9016*			X		X	X
WEISSLACK 9010*	X	X			X	X

PANNEAU DE PORTE, MODÈLES DE CHANTS ET ÂME DES PANNEAUX

FINITION	CHANT				ÂME DES PANNEAUX	
	RP	EC	KR	PK2	RS	LA (DIN-LA)
CPL KARO WHITE				X	X	X
CPL KARO BEIGE				X	X	X
CPL KARO GREY				X	X	X
CPL KARO DARK				X	X	X
CPL GRIS GRAPHITE			X	X	X	X
CPL GRIS POUSSIÈRE			X	X	X	X
CPL GRIS SOIE			X	X	X	X
CPL GRIS ARGENTÉ			X	X	X	X
CPL TOUCH DARKLINE DA/DQ			X	X	X	X
CPL TOUCH SILVALINE DA/DQ			X	X	X	X
CPL TOUCH PEARLLINE DA/DQ			X	X	X	X
CPL TOUCH WHITELINE DA/DQ			X	X	X	X
CPL TOUCH GREYLINE DA/DQ			X	X	X	X
CPL TOUCH CHÊNE SAUVAGE DA/DQ			X	X	X	X
CPL TOUCH CHÊNE NOUEUX DA/DQ	X			X	X	X
CPL TOUCH VIEUX BOIS DE CHÊNE DA/DQ	X			X	X	X
CPL TOUCH OAK WHITE DA/DQ	X			X	X	X
CPL TOUCH OAK CREME DA/DQ	X			X	X	X
CPL TOUCH OAK NATURE DA/DQ	X			X	X	X
CPL TOUCH PIN DA/DQ	X			X	X	X
CPL TOUCH CHÊNE DA/DQ	X			X	X	X
CPL ÉRABLE PUR	X			X	X	X
CPL HÊTRE PUR	X			X	X	X
CPL FRÊNE BLANC	X			X	X	X
CPL CHÊNE	X			X	X	X
CPL BLANC LAQUÉ 9016*			X	X	X	X
CPL BLANC LAQUÉ 9010*	X			X	X	X
BLANC LAQUÉ 9016*			X		X	X
BLANC LAQUÉ 9010*	X	X			X	X

OBERFLÄCHEN

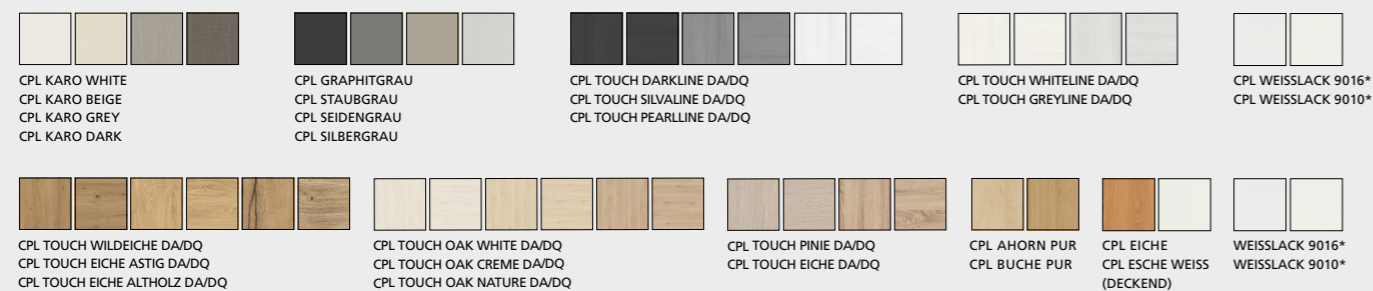

\*ähnlich 9010/9016

FINITIONS

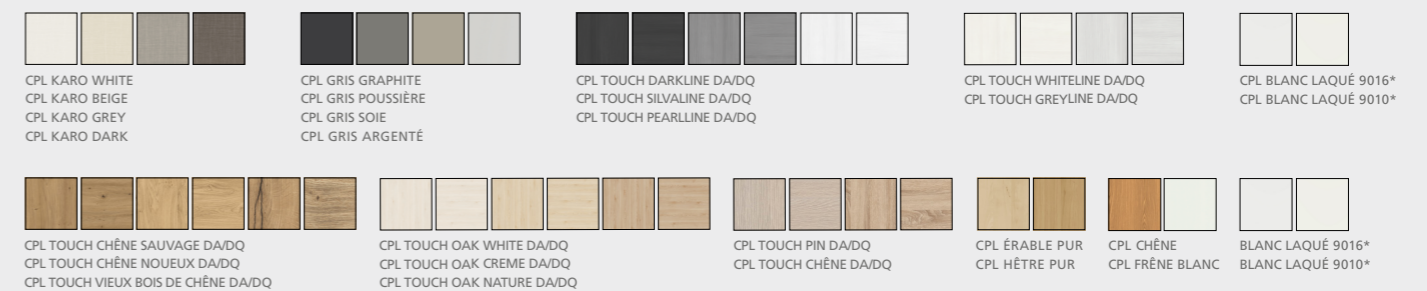

\*IDENTIQUE 9010/9016

## Arbonia Doors-Suisse AG

Chemin du Suchet 1  
1805 Jongny

**Fon** +41 21 967 22 20

**Mail** [vevey@arbonia.com](mailto:vevey@arbonia.com)

**Web** [arbonia-doors.ch](http://arbonia-doors.ch)

Ein Unternehmen der Arbonia Doors

**ARBONIA**   
Doors

Mehr Information  
finden Sie unter



[www.arbonia-doors.ch](http://www.arbonia-doors.ch)

**ARBONIA**   
Doors-Suisse

Stand 02/2024

Drucktechnisch bedingte Farbabweichungen  
sowie Änderungen am Produkt vorbehalten.

Gestaltung: Zertral-Marketing PRÜM